

The dinosaur *Hadrosaurus foulkii*, from the Campanian of the East Coast of North America, with a reevaluation of the genus

ALBERT PRIETO-MÁRQUEZ, DAVID B. WEISHAMPEL, and JOHN R. HORNER



Prieto-Márquez, A., Weishampel D.B., and Horner J.R. 2006. The dinosaur *Hadrosaurus foulkii*, from the Campanian of the East Coast of North America, with a reevaluation of the genus. *Acta Palaeontologica Polonica* 51 (1): 77–98.

Hadrosaurus foulkii was the first dinosaur known outside Europe from partially complete skeletal elements. It is the holotype of the family Hadrosauridae and the subfamily Hadrosaurinae. The history of its discovery and taxonomy is reviewed, and the holotype of *H. foulkii* is redescribed. The holotype of *H. foulkii* lacks distinguishing characters; therefore, this taxon is a *nomen dubium*. It is not synonymous with species of *Gryposaurus* and/or *Kritosaurus*. We also reevaluate the taxonomy and osteology of *H. tripos*, *H. minor*, *H. cavatus*, *H. breviceps*, *H. paucidens*, and *Ornithotarsus immanis*. In agreement with previous studies, these taxa are considered *nomina dubia* due to the absence of distinguishing characters and are therefore referable only to Hadrosauridae indeterminate; *H. paucidens* is referable to Lambeosaurinae indeterminate. Finally, our phylogenetic analysis indicates that the holotype of *H. foulkii* belongs to a member of Euhadrosauria and, tentatively, of Hadrosaurinae.

Key words: Hadrosauridae, Cretaceous, East Coast, North America, phylogeny.

Albert Prieto-Márquez [amarquez@bio.fsu.edu], Department of Biological Science, Florida State University, Tallahassee, Florida, 32306-1100, U.S.A.;

David B. Weishampel [dweisham@mail.jhmi.edu], Center for Functional Anatomy and Evolution, Johns Hopkins University, School of Medicine, Baltimore, Maryland 21205, U.S.A.;

John R. Horner [jhorner@montana.edu], Museum of the Rockies, Montana State University, Bozeman, Montana 59717, U.S.A.

Introduction

During the summer of 1858, William Parker Foulke, a naturalist from Philadelphia, learned of the discovery some 20 years before of fossil bones in the Cretaceous marls of the Woodbury Formation, in Haddonfield, New Jersey (Foulke 1859; see also Weishampel and White 2003). Subsequent excavations at the edge of the old marl pit, on a small tributary of the south branch of Cooper Creek where the bones had originally been found, uncovered a new deposit of bones. Many were large and Foulke contacted Joseph Leidy at the Academy of Natural Sciences in Philadelphia (ANSP). Excavations continued, as did exploration elsewhere in the area (Weishampel and Young 1996; Warren 1998). Foulke and Leidy joined forces in the first description of the bones from Haddonfield at the December 14, 1858 meeting of the ANSP. Foulke (1859) provided some indication of the Late Cretaceous environments there, while Leidy (1859) described the teeth, fragmentary jaw, numerous vertebrae, and partial forelimb and hindlimb from the Haddonfield material for which he proposed the name *Hadrosaurus foulkii*, in honor of his collaborator.

H. foulkii was the first dinosaur known from partially complete skeletal remains discovered in the New World. It rivaled the best-known dinosaurs then recorded from else-

where in the world and provided key information about dinosaurian lifestyles. Thus, due to its historical importance, this taxon is doubtless one of the most celebrated dinosaurs. It is the state fossil of New Jersey (Gallagher 1994) and also the first dinosaur skeleton to be mounted for exhibition, at the Museum of the Academy of Natural Sciences in Philadelphia (Ruschenberger and Tryon 1879; Anonymous 1922). However, the unprecedented richness of the dinosaur discoveries made in the Western Interior of North America and elsewhere in the world during the 19th and 20th centuries produced a shift in the focus of research towards those new findings. The only exceptions are the monograph by Lull and Wright (1942), a study of new hadrosaurid material from New Jersey (Colbert 1948), and an often-cited abstract by Baird and Horner (1977).

Hadrosaurus is also important for being the type genus of the family Hadrosauridae Cope, 1869 and the subfamily Hadrosaurinae Cope, 1869 (Lambe 1918). Hadrosaurids are among the most diverse, specialized, and successful herbivores in the vertebrate communities of the latest stages of the Mesozoic Era. Furthermore, they are probably among the best-understood dinosaurs today in terms of anatomy and evolutionary history (Lull and Wright 1942; Hopson 1975; Ostrom 1961), behavior and life-history strategies (Horner

and Makela 1979; Horner 1982), functional morphology (Weishampel 1981; Norman and Weishampel 1985), paleoecology (Chin and Gill 1996), and taphonomy and sedimentology of their fossil occurrences (Dodson 1971).

Yet the taxonomic status and phylogenetic position of *H. fouldkii* remains enigmatic because this taxon has not been properly diagnosed nor phylogenetically assimilated within Hadrosauridae. This is principally because its remains, considered fairly complete and diagnostic in the 1850s, are actually poorly documented and incomplete in comparison with later discoveries. Therefore, this material has been difficult to interpret in the context of the modern knowledge of these animals. In particular, is *H. fouldkii* really based upon diagnostic material? Is *Hadrosaurus* cogenetic with *Gryposaurus* and/or *Kritosaurus*, as has been proposed by several authors (Baird and Horner 1977; Brett-Surman 1979)? Will a phylogenetic analysis support the inclusion of *H. fouldkii* within Hadrosaurinae? With these questions in mind, we re-evaluate the holotype of *H. fouldkii* from historical, taxonomic, and phylogenetic perspectives. We redescribe in detail its osteology and make comparisons with the current known hadrosaurid material, showing that *Hadrosaurus* is probably not cogenetic with *Kritosaurus* or *Gryposaurus*. We will show that the holotype of *H. fouldkii* lacks distinguishing characters, but that it shares apomorphies with Euhadrosauria (*sensu* Weishampel et al. 1993; the clade formed of Lambeosaurinae and Hadrosaurinae within Hadrosauridae) and, tentatively, with Hadrosaurinae. Finally, we conclude this study with a review of the taxonomy of other species previously referred to *Hadrosaurus* and other taxa from the East Coast of North America.

Institutional abbreviations.—AEHM, Amur Natural History Museum, Blagoveschensk, Russia; AMNH, American Museum of Natural History, New York City, New York, USA; ANSP, Academy of Natural Sciences of Philadelphia, Philadelphia, Pennsylvania, USA; CMN, Canadian Museum of Nature, Ottawa, Canada; MOR, Museum of the Rockies, Bozeman, Montana, USA; NMMNH, New Mexico Museum of Natural History and Science, Albuquerque, New Mexico, USA; OTM, Old Trail Museum, Choteau, Montana, USA; PMU, Museum of Evolution, Uppsala University, Uppsala, Sweden; ROM, Royal Ontario Museum, Toronto, Canada; USA; UCMP, University of California, Museum of Paleontology, Berkeley, California, USA; USNM, National Museum of Natural History, Washington D.C., USA; YPM, Yale Peabody Museum of Paleontology, New Haven, Connecticut, USA.

History of research on *Hadrosaurus fouldkii*

In his first publication on *H. fouldkii*, Leidy (1858, reprinted in 1859) used the relative size of the different regions of the ver-

tebral column of living crocodiles and iguanas to estimate that his new dinosaur was probably 25 feet (8 m) in length. He also noted the resemblance of this animal's teeth and vertebrae with those of *Iguanodon*, a more basal taxon from England. More importantly for paleobiological inferences, Leidy also pointed out the great disparity in length between the forelimb and hindlimb in *H. fouldkii* and suggested that this dinosaur browsed on foliage in a kangaroo-like posture, using its hindlimbs and tail as a tripod support. At the same time, he regarded it as most probably an amphibious animal with fresh-water habits. The presence of *H. fouldkii* in marine sediments suggested that its remains were transported by rivers to be deposited at the bottom of the Cretaceous sea.

Before the discovery of *H. fouldkii*, hadrosaurid dinosaurs were only known from several isolated teeth discovered in the badlands of Montana (*Trachodon mirabilis* Leidy, 1856a) and from two caudal vertebrae and a phalanx from the Lance Formation of Nebraska (*Thespesius occidentalis* Leidy, 1856b). Still, after the discovery of *H. fouldkii*, so little was known about dinosaurs on either side of the Atlantic before the great discoveries of the late 19th and 20th centuries, that *H. fouldkii* was much discussed and figured for several decades after its original description (Leidy 1868a; 1870; Cope 1868, 1869, 1874, 1883; Hawkins 1874, 1875; Lydekker 1888). For example, Leidy returned to *H. fouldkii* in a monograph on the Cretaceous reptiles of the United States (Leidy 1865), which summarized the available information on the geology of the Upper Missouri, New Jersey, Alabama, Texas, and elsewhere in the U.S. Crocodilians, plesiosaurs, mosasaurs, turtles, and dinosaurs were compared with extinct and living forms from the Old and New World. *H. fouldkii* and two other dinosaurs [*Astrodon johnstoni* and *Tomodon horrificus*—later to be renamed *Diplotomodon* by Leidy (1868b)]—were described. This contribution represented Leidy's most detailed and comprehensive osteology of *H. fouldkii*. Comparisons were made not only with modern iguanas and *Iguanodon* in the context of their relationship to herbivory, but also with the teeth of *Trachodon* (*Edmontosaurus*). Without having the benefit of knowing that all hadrosaurids had a dental battery, Leidy argued for the close apposition of each functional tooth and its successors. But beyond these claims about its teeth, Leidy made no effort to infer anything about the paleobiology of *H. fouldkii*. Gone was his earlier speculation about body posture, locomotion, and habitat first introduced in his report of 1858.

In a summary of the then known reptiles from the Mesozoic and Tertiary strata of New Jersey, Cope (1868) devoted a highly speculative section to *Hadrosaurus*. Cope first provided a brief description of the general anatomical proportions of the animal and estimated its total length in 28–30 feet (8.4–9 m), claiming that on land this dinosaur walked at times using only its hindlimbs, flexed at the knees, while trailing its tail. Cope also suggested that it wandered in salt lagoons and used its tail, hindlimbs, and pelvic bones as support to reach upward to the foliage, employing its forelimbs to draw the food to its mouth. Cope even commented on the facial expression of *Hadrosaurus*, pointing out that the “ex-

posure on each side [of] the upper jaw of several rows of shiny teeth...would give [the animal] a somewhat grinning physiognomy..." (Cope 1868: 737). Interestingly, it appears that Cope already contemplated the hypothesis that *Hadrosaurus* lacked muscular cheeks, as has been suggested more recently for ornithischian dinosaurs in general (Papp and Witmer 1998).

In his extensive synopsis of fossil amphibians and reptiles of North America, Cope (1869) erected Hadrosauridae to include *Hadrosaurus* and provided additional osteological details on appendicular elements of *H. fouldkii*, with comparisons with other dinosaurs known at that time such as *Iguanodon*, *Hylaeosaurus*, *Laelaps*, and *Scelidosaurus*. In particular, Cope reconstructed the pelvic girdle of *H. fouldkii*, identifying a previously unrecognized fragment of pubis. However, Cope misplaced the ischium and pubis, reversing their orientation and attaching the former to the pubic peduncle of the ilium and the later to the ischiadic peduncle (Cope 1869: 95, fig. 29). Likewise, Cope reported on the discovery of a fragment of the proximal scapula (Cope 1860: 92, fig. 27). We have been unable to locate this fragment, but Cope's illustration shows an element that certainly may represent the scapula. This partial bone is missing its glenoid and coronoid articulations, but includes the more ventral portion of the acromial process and the ventral half of the blade. Cope also included descriptions of other *Hadrosaurus* species, as well as the erection of additional hadrosaurid taxa from the Cretaceous of the East Coast of North America, such as *O. immanis* and *H. tripos* (see below).

Around the same time, Leidy (1868a) again compared the dentition of *H. fouldkii* with that of *T. mirabilis* and considered both forms as probably only specifically separated, contemplating the possibility that *Trachodon* might be cogenetic with *Hadrosaurus*. However, in his 1869 monograph, Cope synonymized *Trachodon* and *Thespesius* with *Hadrosaurus* and included *T. mirabilis* under this last. Two years later, Leidy rejected Cope's synonymy of *Hadrosaurus* with *Thespesius*, and, while recognizing the similar tooth morphology in these animals (and *Trachodon*), he emphasized caudal vertebral differences that he thought could be used to distinguish both taxa (Leidy 1870).

In a later paper, Cope (1874) listed several fragmentary remains from Cretaceous strata of the Western United States under *Hadrosaurus*, including the two caudal vertebrae and phalanx of the type of *T. occidentalis* of Leidy (1856b) and the type of *Claosaurus agilis*, from the Niobrara Formation of Western Nebraska (Marsh 1872; Carpenter et al. 1995). Waterhouse Hawkins later published a few remarks on the correct identification and articulation of "pseudo-clavicles" as pelvic elements (his "ischiatric bones") in *H. fouldkii*, drawing comparisons with those of the ostriches and rheas (Hawkins 1874, 1875).

In 1883, Cope revisited *H. fouldkii* and compared it with other hadrosaurids, particularly with the skull and dentition of a complete *Edmontosaurus* skeleton [AMNH 5730, referred by Cope to *Diclonius mirabilis*, but later regarded as

the type of *Anatolian copei* by Brett-Surman (1990)]. Again, Cope speculated on the paleobiology of these animals, concluding that *Hadrosaurus* and its relatives would feed on soft vegetation (as well as fishes without bony scales) because he regarded their dentitions as too weak to process tree branches and harder plant material. A few years later, Lydekker (1888) synonymized the genus *Hadrosaurus* with *Trachodon* on the basis of their dentitions, echoing Leidy (1868a) while providing a brief description of the teeth of the former.

In their monograph on North American hadrosaurids, Lull and Wright (1942) reexamined the anatomy and relationships of *H. fouldkii*, as well as that of more poorly known hadrosaurid species that had been discovered along the East Coast since the 1850s. Although they paraphrased much of Leidy's earlier descriptions, Lull and Wright attempted to assimilate *H. fouldkii* into the relationships of the many North American hadrosaurids that had been discovered up to that time. First asserting that "the generic distinction of *Hadrosaurus* rests on an insecure basis owing to the absence of a skull" (Lull and Wright 1942: 138), they provided skeletal evidence that it was "a flat-headed" form (i.e., a hadrosaurine) on the basis of the morphology of its ischium, forelimb proportions, and shape of the teeth. Lull and Wright compared *H. fouldkii* with better-known hadrosaurids, particularly *Anatosaurus annectens* (now *Edmontosaurus annectens*; Rozhdestvensky 1968; Weishampel and Horner 1990; Horner et al. 2004). They regarded these two forms as distinct, based on differences in the morphology of the caudal vertebrae, middle dorsal spines, ilia, and teeth, as well as the remoteness in time and space between them. Finally, they considered the other East Coast species that had been referred to or had been closely allied with *H. fouldkii* up to that time. Two of these, *Ornithotarsus immanis* and *H. tripos*, were named by Cope in his comprehensive study of the extinct non-mammalian tetrapods of North America (Cope 1869).

O. immanis was based on a partial tibia, fibula, astragalus, and calcaneum from the Monmouth Formation near Keyport, New Jersey, while *H. tripos* consisted of caudal vertebrae from the Black Creek Formation of Sampson County, North Carolina. A year later, *H. minor* was erected by Marsh (1870) for several dorsal vertebrae thought to come from the Navesink Formation near Barnsboro, New Jersey. Finally, Cope (1871) described *H. cavatus*, known only from several caudal vertebrae from near this same locality. Clearly, all of these taxa were based on poor material (considering that many hadrosaurid species were now known from complete skulls and sometimes complete skeletons) and Lull and Wright (1942) regarded each to be established on an insecure basis. Shortly after the publication of Lull and Wright (1942), Colbert (1948) described new material from the Navesink Formation of New Jersey, which he referred to *H. minor*.

In his detailed analysis of the cranial anatomy of North American hadrosaurids, Ostrom (1961) recognized the incomplete nature of the holotype of *H. fouldkii* in the context of being the type genus of Hadrosauridae and Hadrosaurinae, particularly that the former does not allow referral to either

flat-headed, solid-crested or hollow-crested forms based on direct cranial data. However, Ostrom opted for the conservative solution of assuming that *H. foulkii* was a hadrosaurine.

Baird and Horner (1977) provided a brief statement about *H. foulkii* and other Late Cretaceous dinosaurs from the East Coast in a brief abstract. Their reappraisal of these early finds includes referral of *O. immanis* and perhaps *H. cavatus* to *H. foulkii*. More importantly, they suggested that *Gryposaurus* (*Kritosaurus* in their abstract), from the Western Interior of North America, was a junior synonym to *Hadrosaurus*, although they provided no characters to support this idea. They also thought that Colbert's (1948) specimen of *H. minor* might be referable to *Edmontosaurus*, as *E. minor*.

Since then, most studies including *H. foulkii* have concentrated in comparing this taxon with *Gryposaurus*, some of them concluding that these taxa are different (Carpenter 1982; Davies 1983), whereas others regarded these hadrosaurids as closely related (Brett-Surman 1975, 1989; Wagner 2001) or synonymous (Brett-Surman 1979) (see below for details on this matter). In their review of Hadrosauridae, Weishampel and Horner (1990) regarded *H. foulkii* as a valid taxon and as a "gryposaur" closely related to taxa such as *Gryposaurus notabilis* and *Aralosaurus tuberiferus*. However, no synapomorphies between *H. foulkii* and species of *Gryposaurus* were provided. Likewise, *O. immanis* was synonymized with *H. foulkii*. More recently, Horner et al. (2004) considered the possibility that *H. foulkii* would have a basal unresolved relationship within Euhadrosauria (see Weishampel et al. 1993), based on relative decrease in tooth size, the presence of a single strong carina on dentary teeth, and the possession of a distally unexpanded shaft (a condition suggested by Lull and Wright 1942).

Systematic paleontology

Dinosauria Owen, 1842

Ornithischia Seeley, 1887

Ornithopoda Marsh, 1881

Ankylopollexia Sereno, 1986

Hadrosauroidae Sereno, 1986

Hadrosauridae Cope, 1869

Hadrosaurus Leidy, 1858; *nomen dubium*

Type species: Hadrosaurus foulkii Leidy, 1858.

Hadrosaurus foulkii Leidy, 1858

Holotype: ANSP 9203: fragment of the lateral wall of the middle region of a right maxilla. ANSP 9204: lateral fragment of ectopterygoid shelf of a left maxilla. ANSP 9202: fragments of dental lamina and edentulous alveoli. ANSP 9201: isolated maxillary and dentary teeth. ANSP 10005: three partial cranial dorsal vertebrae, three proximal caudal centra, nine proximal to middle caudal centrum, including an almost complete middle caudal vertebra, and numerous vertebral fragments, a partial right coracoid, left humerus, left radius, left ulna, left ilium, right ischium, right partial pubis, and a partial left hind limb represented by a

femur, tibia, nearly complete fibula, metatarsals II and IV, and pedal phalanx III-1.

Type locality: Haddonfield, New Jersey, East Coast of the United States of America.

Type horizon: Woodbury Formation, Campanian, Upper Cretaceous.

Skull and mandible

Maxilla (Fig. 1B).—One of the two preserved maxillary fragments (ANSP 9203) corresponds to the lateral wall of the middle region of a right maxilla, ventral to the dorsal process. The lateral surface is partially preserved and most of its rostradorsal area, where the articulation surface for the jugal is located, appears heavily abraded and covered with plaster. Ventrally, the specimen is convex, corresponding to the ventral margin of the maxilla and the alveoli. Caudally from that convexity, the lateroventral surface becomes concave and separated from the dorsal portion by a well-developed ridge. This ridge is caudally continuous with the lateral margin of the ectopterygoid shelf. Dorsal to this ridge, the lateral surface of the maxilla slopes caudoventrally and, in the complete maxilla, it would have continued as the ectopterygoid shelf. The dorsal margin of ANSP 9203 is broken ventral to the rise of the dorsal process of the maxilla. On the medial side, there is a dorsoventrally convex and smooth dorsal margin, which is as thick as 25% of the total dorsoventral depth of the specimen. This margin is dorsal to the alveoli of the dental battery. Thirteen alveoli are preserved on the medial side of the specimen, but only eight of them are nearly complete. This specimen was described and figured by Leidy (1865) as a fragmentary dentary (pl. 13: 24, 25). Later, Lull and Wright (1942) correctly recognized it as a maxillary fragment. The only location in a dentary where ANSP 9203 could correspond is the lateral surface where the coronoid process begins to rise dorsally; the observed ridge would then correspond to the base of the rise of the coronoid process. However, in ANSP 9203 the long axis of the alveoli is perpendicular to the ridge, whereas in a hadrosaurid dentary the coronoid process begins rising obliquely to the long axis of the alveoli. Furthermore, the ridge in ANSP 9203 is too sharp and well defined, and the space between it and the alveolar margin is too small to be the space between the coronoid process and the alveolar margin. Thus, we rule out the possibility that ANSP 9203 could be from a dentary. In the maxilla, another alternative is that ANSP 9203 could be part of the rostradventral process. However, in that case the line of dental foramina should follow an arch directed rostradventrally and the alveoli height should gradually diminish rostrally. Likewise, on the medial side, the margin dorsal to the line of dental foramina in the rostral region of maxilla is flat or concave. In ANSP 9203 this margin is convex, as in the middle region of hadrosaurid maxillae.

Another maxilla (ANSP 9204) consists of the lateral portion of a left ectopterygoid shelf (Fig. 1B₁ and B₂). This specimen preserves the caudal section of the lateral convex border of the shelf, which gradually thickens dorsoventrally to

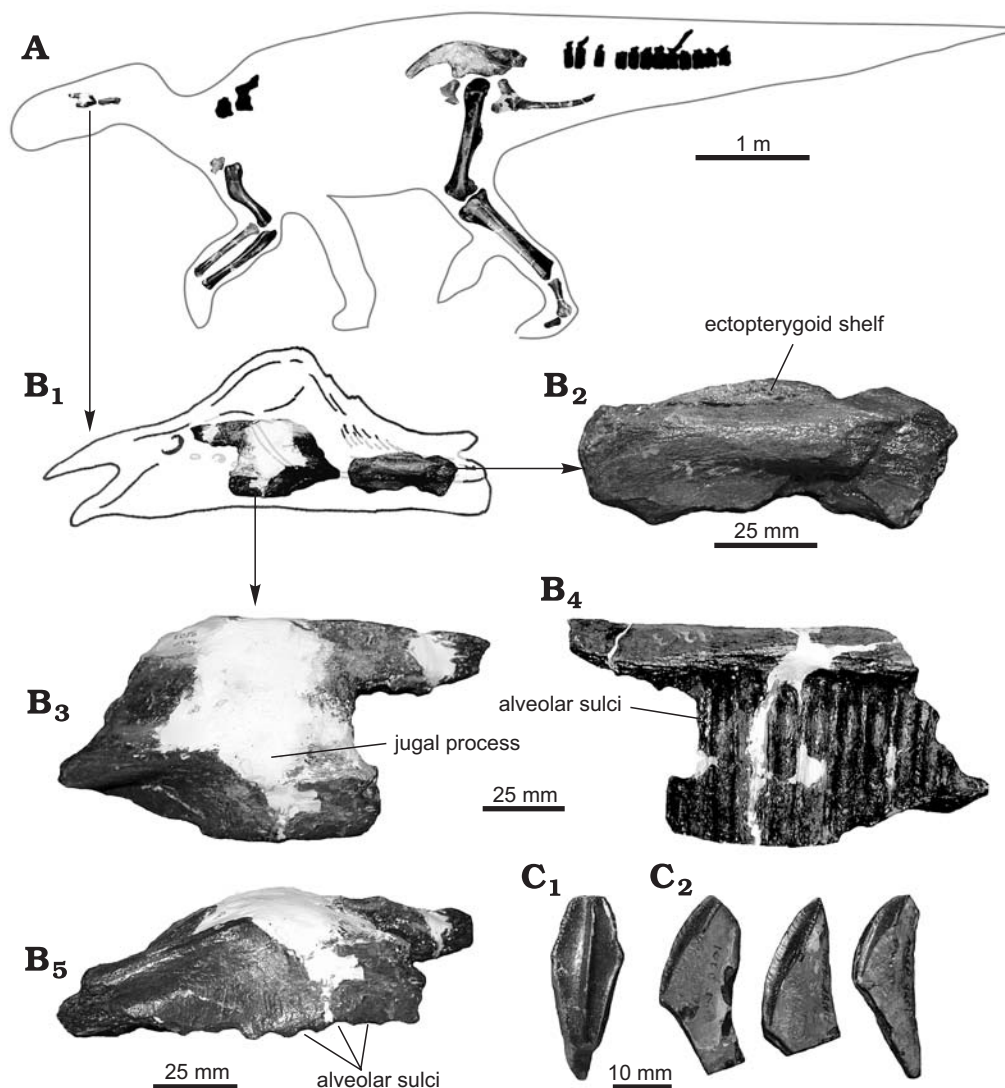

Fig. 1. *Hadrosaurus fouldii* Leidy, 1858, Haddonfield, New Jersey, U.S.A., Woodbury Formation, Campanian, Upper Cretaceous. **A.** Composite skeleton with the location of the preserved bones. **B.** Maxillary fragments (ANSP 9203, reversed, and 9204) placed on a generic hadrosaurid maxilla (**B₁**); ANSP 9204 in lateral view (**B₂**); ANSP 9203 in lateral (**B₃**), medial (**B₄**), and ventral (**B₅**) views. **C.** Dentary teeth (ANSP 9201) in lingual (**C₁**) and mesial or distal (**C₂**) views.

wards its caudal end. The medial side includes portions of eight alveoli.

Dentition (Fig. 1C).—Maxillary and dentary teeth are found isolated from the jaw material. Dentary teeth have elongated diamond-shaped crowns, with a 2.65 average length/breadth ratio. A single carina longitudinally bisects the crown. Denticles are present on the edges of the apical half of the crown and absent around the basal half. There are from 14 to 16 papillae on each side. Papillae increase in size towards the apex of the crown. The crown forms a 125° angle with the root (measured along the mesolabial or distolabial border of the enamel, which is the supplementary angle to the one measured by Horner 1992). In this regard, *H. fouldii* differs from taxa such as *B. canadensis* (140° in MOR 1071) and *Edmontosaurus* sp. (135° in CMN 8744), but compares well with *P. blackfeetensis* (120° in MOR 447). The roots of maxillary teeth expand abruptly to support the crowns. Maxillary teeth have papillae only around the edges of the ventral half of the crown, as many as in the dentary teeth. The

single median carina does not reach the apical end of the crown, unlike in the dentary teeth. The length/width ratio of maxillary teeth is 2.5.

Axial skeleton

Dorsal vertebrae—In *H. fouldii*, little more is preserved than the centra and the proximal region of neural spines and diapophyses. As in other hadrosaurids, cranial dorsal centra are heart-shaped in caudal view and moderately opisthocelous. In ventral view, the centrum of the cranial dorsals is hourglass-shaped. The neural canal is oval and slightly wider mediolaterally than dorsoventrally. The centrum of the caudal dorsals is more oval and less heart-shaped. The ventral portion is less constricted mediolaterally and does not show the keel seen in the cranial dorsals. The centrum is higher, as long proximodistally than wide mediolaterally. The centrum of the caudal-most dorsals is craniocaudally shorter in relation to that in the middle and cranial dorsals. The parapophyses are reduced in size, forming two oval excavations that

face craniolaterally adjacent to the craniodorsal border of the medial segment of the diapophyses.

Caudal vertebrae—Caudal centra are mediolaterally wide and hexagonal in outline, as in other hadrosaurids. Proximal caudal centra are craniocaudally compressed, but become gradually more elongated distally along the series. More distal caudals show a more perfect hexagonal contour, with demarcated edges. The transverse processes are narrow and rod-like. On the proximal caudals, the distal end of the diapophysis is curved ventrally. The neural spine is transversely thick at its mid length, ellipsoidal in cross section, and projects caudodorsally. The neural canal is circular and relatively small. The zygapophyses are small and oval facets. Proximally, the prezygapophyses are more circular than the postzygapophyses. The prezygapophyses are supported and projected distodorsally by two short prezygapophyseal processes. The space between the prezygapophyses is a U-shaped, concave surface. Distal caudal centra have strongly concave lateral sides. They are platycoelous, with only slightly concave distal surfaces.

Appendicular skeleton

Coracoid (Fig. 2D, E).—Both Leidy (1858, 1865) and Lull and Wright (1942) did not recognize this element among the holotype specimens. Actually, it is represented by a fragment corresponding to the caudoventral region of a right coracoid. Most of the glenoidal facet is present. This surface is D-shaped, concave, and slightly wider mediolaterally than dorsoventrally, as in other taxa such as *B. canadensis* (MOR 794), *E. regalis* (CMN 2289), *S. orborni* (AMNH 5271), and *G. latidens* (AMNH 5465). Cranially, the element narrows mediolaterally to reach a breadth less than half that of the glenoid facet. The lateral surface of the specimen is nearly flat, while the medial side is slightly concave. Cranioventrally, only a portion of the ventral process of the coracoid is preserved. This process is slightly narrower mediolaterally than the cranial region of the specimen. Craniodorsally, the ventral half of the coracoid foramen is present and accounts for nearly one third of the craniocaudal width of the specimen.

Humerus (Fig. 2C).—This element is represented by a complete left humerus, well described by Leidy (1865: figs. 1–4, pl. 14) and Lull and Wright (1942). It measures 555 mm in length. The deltopectoral crest has a rounded, smooth margin at its junction with the distal half of the humerus. This crest, unlike those of other euhadrosaurians [but like in *Telmatosaurus transsylvanicus* (Weishampel et al. 1993)], does not extend down until or below midshaft. The craniocaudal breadth of the humerus at the level of the deltopectoral crest is less than twice the diameter of the shaft, but far from the small width exhibited by *T. transsylvanicus*. ANSP 10005 is a more gracile humerus than the humeri of other hadrosaurids such as species of *Kritosaurus*, *Gryposaurus*, *Maia-saura*, *Prosaurolophus*, *Edmontosaurus*, *Brachylophosau-*

rus and *Lambeosaurinae*. The muscle scar on the caudal side of the element for the latissimus dorsi muscle is poorly developed; most hadrosaurid humeri of similar size have a more developed scar, consisting of a rugose swelling surrounded by an oval depression (e.g., *E. regalis*, CMN 2289; *G. latidens*, AMNH 5465; *P. blackfeetensis*, MOR 455; *B. canadensis*, MOR 794). The humeral head is massive, rounded, and triangular in proximal view.

Radius (Fig. 2A).—ANSP 10005 includes a complete left radius. Measuring 520 mm in length, the specimen is nearly as long as the ulna. The radius is robust, with a shaft at most 12.5 times longer than thick at the minimal midshaft diameter. In many hadrosaurid radii the ratio of radius length/minimum shaft thickness ranges from 15 to almost 19, although there are some cases where the radius is as robust as in ANSP 10005 (e.g., *E. regalis*, CMN 2289, with a 12.3 ratio). The proximal end of the radius of *H. foulkii* expands abruptly and is cup-like. The proximal surface is flat and subrectangular. Ventrally, the proximal end forms a thick, keel-like prominence for articulation with the U-shaped proximodorsal surface of the ulna. Proximal to this prominence, the ventral surface is concave. Distally, the radius thins abruptly and becomes a subcylindrical long shaft. The mid-third of the radius is compressed in a lateroventral-mediadorsal direction. Along its distal third, the shaft becomes subtriangular in cross section and flattens on the lateroventral side that articulates with the ulna. Gradually the radius expands dorsoventral and mediolaterally towards the distal end. The distal end is subtriangular, with rounded corners.

Ulna (Fig. 2B).—The ulna is slightly longer than the humerus and measures 590 mm in length. Like the radius, the ulna has a thick shaft relative to its length, but other taxa have both more slender (e.g., *P. blackfeetensis*, MOR 549) and more robust ulnae (e.g., *E. regalis*, CMN 2289). Proximally, the medial flange extends mediadorsally for slightly less than the maximum mediolateral width of the proximal end of the ulna. The medial flange forms a 160° angle with the dorsal surface of the proximal end of the ulna. The lateral flange is reconstructed dorsally with plaster. The cubital fossa is deep. The olecranon process is wider mediolaterally than long craniocaudally, although it is slightly abraded. The middle third of the ulna is 60% thinner dorsoventrally than the proximal end. This decrease in breadth is very gradual. The distal end is dorsally excavated to receive the distal end of the radius. The lateral edge of the distal end is expanded, but 20% shallower dorsoventrally than the proximal end of the ulna. The medial edge of the distal end of the ulna is much less expanded than the lateral border.

Ilium (Fig. 3A).—The body of the ilium has a smoothly curved craniodorsal edge. Plaster reconstruction contributes to this profile along the craniodorsal border of the ilium, cranial to the dorsal surface of the supracetabular process. The proximal region of the preacetabular process is very deep in lateral view, accounting for 66% of the dorsoventral depth of

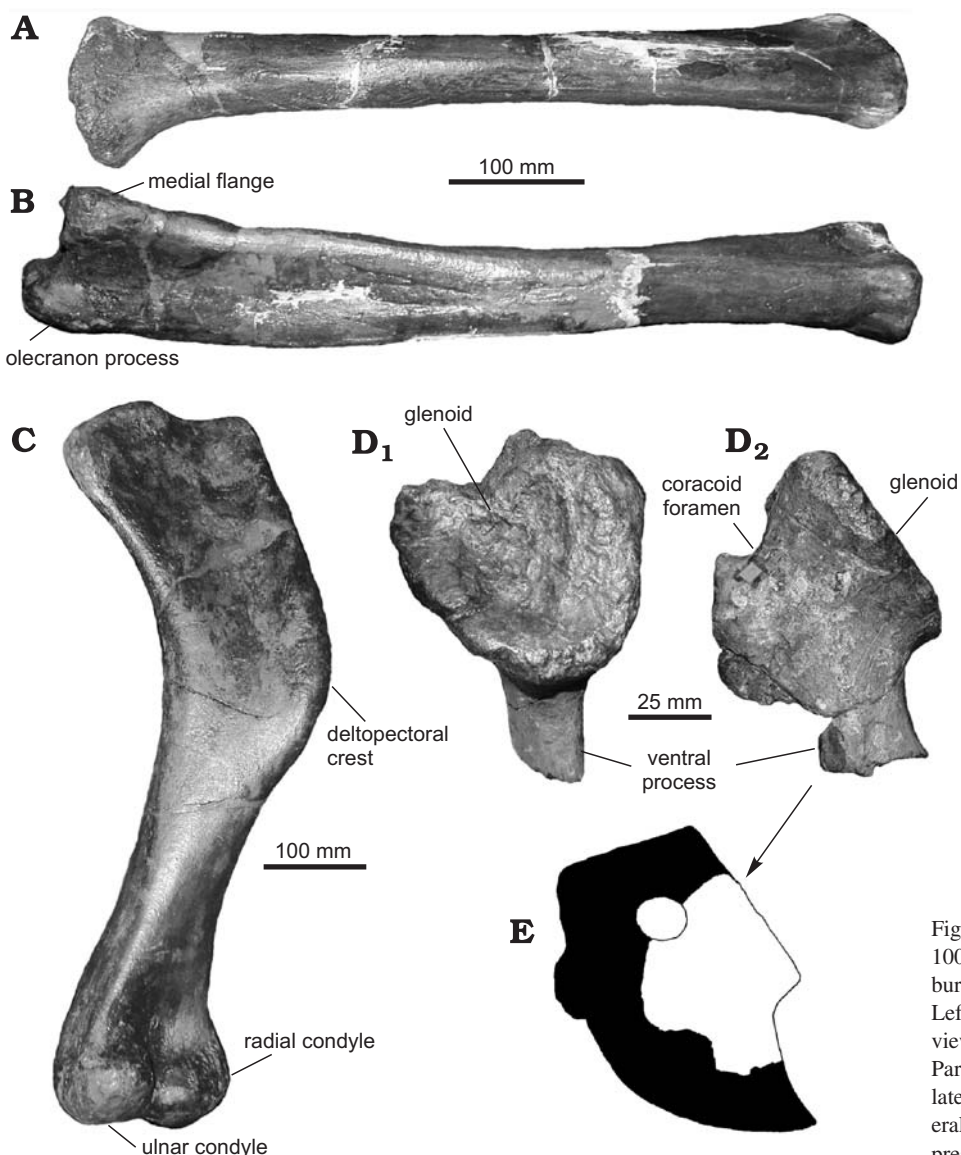

Fig. 2. *Hadrosaurus fouldii* Leidy, 1858 (ANSP 10005), Haddonfield, New Jersey, U.S.A., Woodbury Formation, Campanian, Upper Cretaceous. **A.** Left radius in dorsal view. **B.** Left ulna in medial view. **C.** Left humerus in anteromedial view. **D.** Partial left coracoid in glenoid (**D₁**) and cranio-lateral (**D₂**) views. **E.** Schematic drawing of a generalized hadrosaurid coracoid showing in white the preserved region displayed in **D.**

the element at this level (however, see discussion below). Cranioventrally, the preacetabular process tapers gradually. In other hadrosaurids there is a dorsoventral thickening of the preacetabular process near its distal end, ventrally at the level of the pubic peduncle. In *H. fouldii* this thickening appears to be missing, but the cranioventral end of the preacetabular process is incomplete, which makes it impossible to verify the condition here. On the medial side of the ilium there is a ridge for rib articulation that projects medioventrally and extends caudally into the body of the bone. Cranially the ridge bisects the dorsoventral breadth of the preacetabular process. The supracetabular process (“antitrochanter”) is massive and its lateral surface is incompletely preserved. Ventral to the supracetabular process, the lateral surface of the ilium is slightly concave. The pubic peduncle is larger than the ischial peduncle, which forms a rugose prominence. The cranioventrally-directed pubic peduncle is relatively gracile and triangular in lateral profile. It is cranioventrally directed.

The postacetabular process is incomplete distally incomplete, lacking most of its length. This process twists medio-laterally, as in other hadrosaurids. In cross section, the postacetabular process is D-shaped, with a convex medial side.

Ischium (Fig. 3C)—ANSP 10005 includes a right nearly complete ischium. The ischial shaft is ellipsoidal in cross section and curves caudodorsally. With the exception of three isolated specimens (see discussion), in other hadrosaurids the shaft is straight (e.g., *Hypacrosaurus stebingeri* and *M. peeblesorum*) or slightly bent caudoventrally at the distal tip (e.g., *B. canadensis*). The diameter of the ischial shaft in *H. fouldii* is constant until it narrows near the incomplete distal end. The preserved shaft is at least four times as long as the proximal region of the ischium. The expanded cranial region of the ischium arches dorsally to form the iliac peduncle. Ventrally, it projects cranially into the pubic peduncle. The ischium has well-developed iliac and pubic peduncles, although the area leading to the pubic peduncle is mostly reconstructed. The

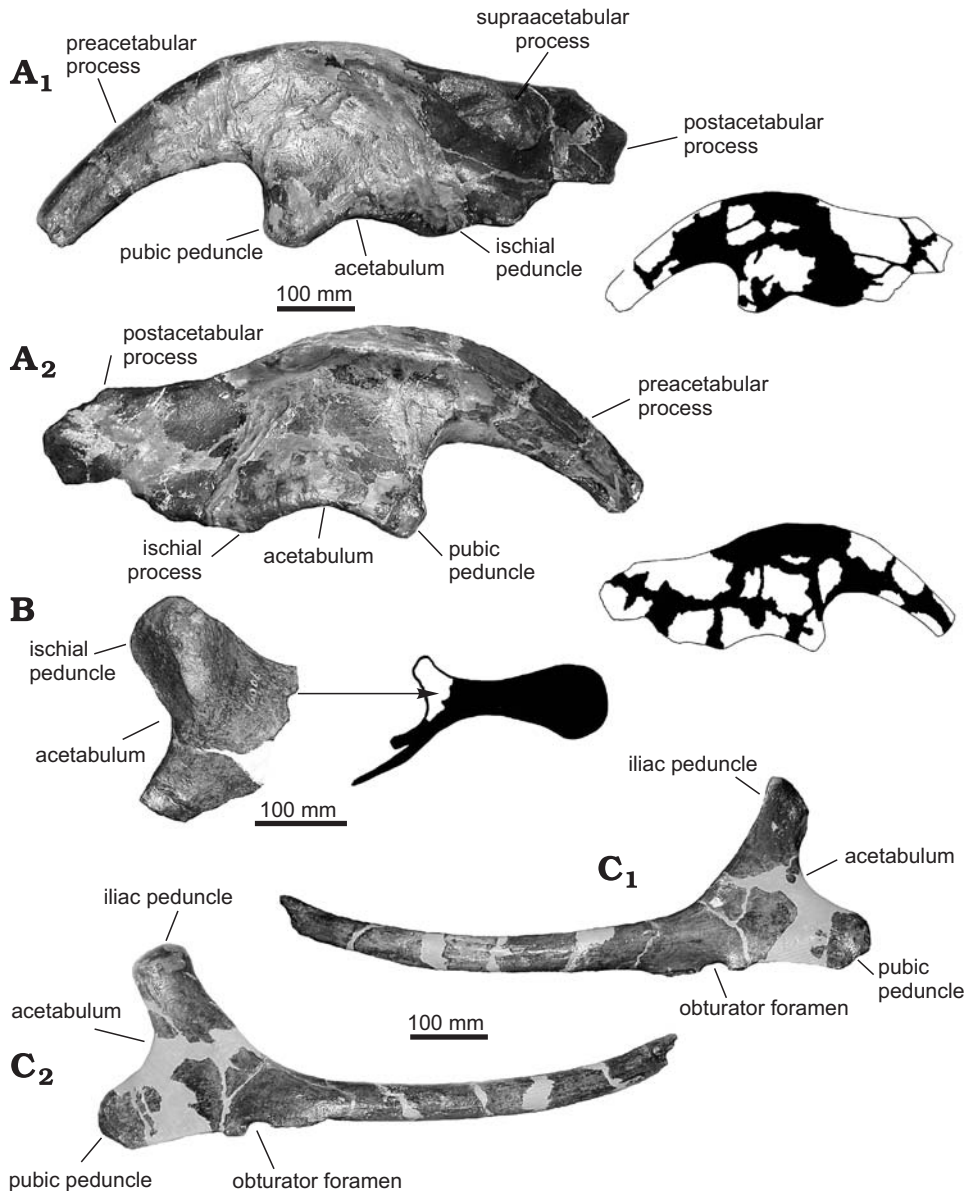

Fig. 3. *Hadrosaurus foulkii* Leidy, 1858 (ANSP 10005), Haddonfield, New Jersey, U.S.A., Woodbury Formation, Campanian, Upper Cretaceous. **A.** Left ilium in lateral (A_1) and medial (A_2) views, accompanied by drawings showing in black the areas containing plaster reconstruction; white represents bone. **B.** Fragment of right pubis in lateral view; the arrow points to the corresponding region in a generalized complete hadrosaurid pubis. **C.** Right ischium in lateral (C_1) and medial (C_2) views.

wide pubic peduncle forms a blade that is slightly expanded dorsoventrally at its end. The iliac peduncle is subrectangular and projects craniodorsally from the dorsal portion of the ischial blade. The craniodorsal end of the iliac peduncle is mediolaterally and dorsoventrally expanded. The obturator process is partially preserved and leaves an asymmetric obturator notch. The process cranial to the notch is also missing.

Pubis (Fig. 3B)—This bone is only represented by a fragment of the right pubis and was not recognized in most previous studies (Leidy 1858, 1865; Lull and Wright 1942). However, Cope (1869) identified this element correctly. It consists of a complete iliac peduncle and a partial ischial peduncle. The cranial portion is broken where the neck of the pubis builds toward the prepubic blade. The ischial peduncle is triangular in cross section and is larger and more massive than the ischial peduncle, extending caudodorsally from the lateral face of the pubis. The iliac peduncle has the dorsal

outline of an equilateral triangle. Its dorsal surface is flat and caudomedially oriented. The iliac peduncle is roughly tetrahedral with the apex pointing ventrally, laterally rotated around the dorsoventral axis. The largest facet is slightly concave, facing caudolaterally about 45° from the mediolateral plane. This surface, dorsoventrally crossed by numerous striations, has the outline of an inverted teardrop.

Femur (Fig. 4A).—This element measures 1055 mm and is 12% longer than the tibia (Lull and Wright 1942). The femur is columnar and robust, straight along its proximodistal length and mediolaterally compressed. In caudal view, the element curves slightly medially. The proximal segment of the shaft is more mediolaterally expanded and wider cranio-caudally than the distal portion of the femur. The massive head projects medially 90° from long axis of the femur. Laterally, the large greater trochanter is much more expanded cranio-caudally and proximodistally than the head, but it is

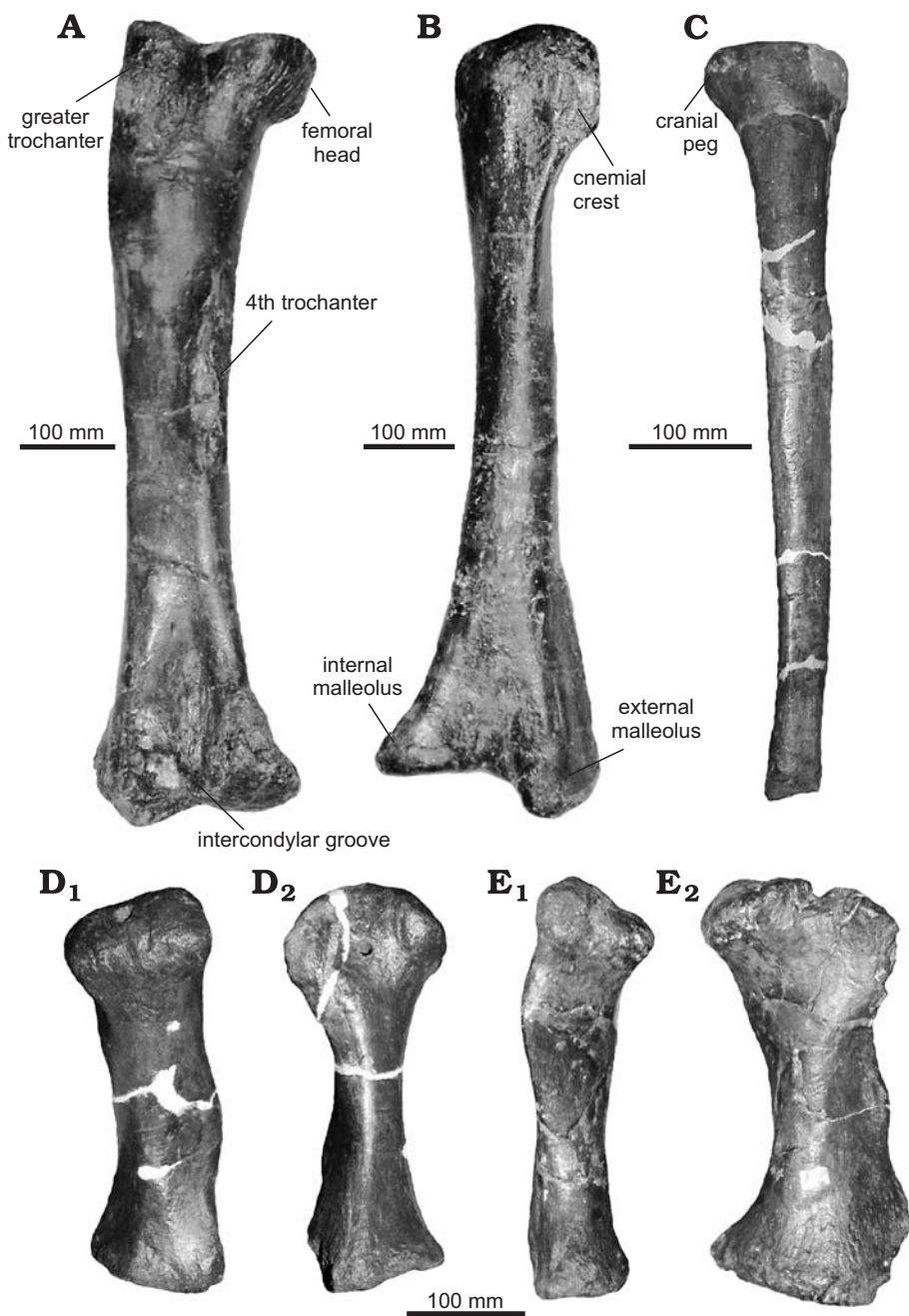

Fig. 4. *Hadrosaurus fouldkii* Leidy, 1858 (ANSP 10005), Haddonfield, New Jersey, U.S.A., Woodbury Formation, Campanian, Upper Cretaceous. **A.** Left femur in caudal view. **B.** Left tibia in cranial view. **C.** Left fibula in lateral view. **D.** Left metatarsal IV in dorsal (D_1) and lateral (D_2) views. **E.** Left metatarsal II in dorsal (E_1) and medial (E_2) views.

mediolaterally compressed. The cranial trochanter is proximodistally elongated, thinner proximally than distally. The fourth trochanter comprises little less than one third of the total proximodistal length of the femur. It is incompletely preserved along its caudal edge. The cross section of the shaft is subrectangular, with shorter cranial and caudal sides. The distal condyles have an H-shaped outline in distal view and enclose a deep and wide intercondylar groove. The lateral condyle is missing its caudal margin. Both condyles are mediolaterally compressed and curve caudodorsally to form thick, rounded caudodorsal and caudoventral borders.

Tibia (Fig. 4B).—The tibia measures 933 mm in length (Lull and Wright 1942). The cnemial crest is very robust and only

moderately curved cranio-laterally. The proximal caudolateral condyles are as thick as the cnemial crest, the medial condyle being thicker. The shaft of the tibia thins remarkably towards its mid length, where both its craniocaudal and mediolateral diameters are one third of the maximum width of the proximal and distal ends. In medial view, the outline of the caudal surface is nearly straight, whereas the cranial side is slightly curved as the shaft thins. However, in cranial view both the medial and lateral sides of the shaft are straight until they greatly expand distally.

Fibula (Fig. 4C).—This bone is among the most robust of known hadrosaurid fibulae, where the ratio of the minimum craniocaudal width/maximum width of proximal end is 0.34.

This figure is comparable to that in *G. notabilis* (YPM 16970, with a ratio of 0.36) and *B. canadensis* (MOR 794, ratio of 0.35), but unlike other taxa such as *C. casuarius* (AMNH 3971, ratio of 0.25), *H. altispinus* (AMNH 5217, ratio of 0.28), and *E. regalis* (CMN 2289, ratio of 0.27). ANSP 10005 is missing the distal end. The proximal end shows a prominent cranial corner, which is slightly bent medially over a relatively deep excavation. The caudal corner of the proximal end is reconstructed with plaster. The medial excavation of the proximal half of the fibula is triangular in outline and gradually disappears distally. The fibula is mediolaterally compressed proximally and its craniocaudal breadth decreases gradually distally; the thinnest portion is reached near the distal end, where the mediolateral width is one third of that of the proximal end. Mediolaterally, the fibula is most compressed at its mid length. The distal third is medially twisted relative to the long axis of the bone and is triangular in cross section.

Metatarsal II (Fig. 4E).—This element is a mediolaterally compressed and proximally and distally expanded. The medial face is proximodistally concave, while the articulating lateral surface is convex at its mid length. The craniomedial flange forms a medially flattened sharp edge. The lateral surface of the flange has a rugosity that extends distally. On the lateroplantar border of the bone there is a smaller flange, forming a semicircular rugose edge. The proximal surface is cranioplantarly elongated and oval in outline. Its ventral edge is partially preserved. The proximal face is concave at its center and rugose. Its long axis is laterally tilted relative to the cranioplantar axis of the distal surface. The distal fourth of the metatarsal is slightly wider mediolaterally and medially directed; the distal surface faces mediodistally. The distal surface is trapezoidal, being the mediolaterally widest region of the metatarsal. Its plantomedial corner is incompletely preserved.

Metatarsal IV (Fig. 4D).—This element is cranioplantarly compressed and has expanded proximal and distal ends. The mid-proximal medial flange is thick and prominent. The proximal surface is D-shaped. The distal face is subtrapezoidal and more expanded mediolaterally than in metatarsal II. The long axis of the distal surface is lateroventrally rotated a few degrees relative to the long axis of the proximal face. Both the dorsal and ventral surfaces are slightly concave proximodistally, especially the dorsal one. The medial flange comprises the dorsoplantar thickness of the short shaft and extends along 40% of the proximodistal length of the element. The flange is positioned closer to the proximal edge of the bone than to the distal end. The medial surface of this flange is very rugose.

Pedal phalanx III1—Phalanx III1 is subrectangular in dorsal view and it is almost symmetrical relative to a parasagittal plane, except for the slightly more dorsoplantarly compressed proximolateral border. The proximal end is more mediolaterally expanded than the distal end. The dorsal surface is

flattened, slightly concave with a gentle proximolateral slope. The plantar surface is slightly concave mediolaterally, except for the proximal region, where it becomes convex. The concave proximal surface is subellipsoidal, with a deeper medial edge. The plantar edge is slightly concave at the center. The distal surface is semicircular and slightly crescentic, with a flat dorsal border and a concave ventral side. Near the distal end, there is a convex rugosity on the lateral side of the bone.

Is the holotype of *Hadrosaurus foulkii* diagnostic?

Since the early works on *H. foulkii*, many of the authors who regarded this taxon as different from *Gryposaurus* and *Kritosaurus* have also considered it to be diagnostic (Brett-Surman 1979; Weishampel and Horner 1990; Horner et al. 2004). However, no formal diagnosis has been published since the nineteenth-century studies. Indeed, the fragmentary and poorly represented cranial remains of the holotype of *H. foulkii* do not allow it to be distinguished from the remaining hadrosaurids. In the postcrania, no element has derived characters exclusively found in *H. foulkii*, although, at first glance, the ilium and ischium may appear to have potentially autapomorphic morphologies. Yet none of these elements is diagnostic at lower taxonomic levels.

The ilium has a preacetabular process that is very deep proximally (66% as deep as the body of the ilium at that level) and that tapers continuously distally. However, the great depth of this process is not unique to *H. foulkii*. Other taxa display proximal preacetabular processes as deep or deeper than ANSP 10005 (e.g., *C. casuarius* ANSP 16969, with 66% of the dorsoventral depth of the ilium; *H. stebingeri*, MOR 549, 65%; *Olorotitan arharensis*, AEHM 2/845, 68%; and *Tanais sinensis*, PMU R242, 67%). Likewise, the extensive plaster reconstruction along the cranioventral edge of the proximal and lateral region of the preacetabular process may have accentuated its depth (Fig. 3A). The continuous cranioventral tapering of the ilium does not show the ventral thickening commonly observed in other hadrosaurids. However, the absence of this thickening may be only apparent because the distal-most end of the preacetabular process is missing.

The shaft of the ischium of *H. foulkii* is unusually curved upward distally. However, there are at least four other hadrosaurid specimens with this condition. One of them is an ischium from a hadrosaurine, referred to *Kritosaurus* sp., from the San Miguel Formation (uppermost Campanian), near the town of Sabinas, Coahuila, Mexico (Hernández et al. 2003). Another specimen is AMNH 5277, a right ischium from an indeterminate hadrosaurid collected in 1912 from Maastrichtian strata in the Red Deer River area (Tolman Ferry locality), Alberta, Canada. A third example is an ischium from an unnamed hadrosaurid from the Campanian Judith River Forma-

tion of Montana (UCMP 137273). Finally, there is an ischium from the Middle and/or Upper Campanian of the upper Shale Member of the Aguja Formation from Texas (TMM 42309-4) referred to *Kritosaurus* cf. *navajovius* (Wagner 2001), which has a slight upward curvature of the shaft. This material shows indication of deformation (Wagner, personal communication), so that the curvature of the ischial shaft is likely the result of distortion. None of the skeletal elements associated to these ischia allows correspondence with or discrimination from *H. fouldii*, with the exception of the pubis illustrated in Hernandez et al. (2003). This element shows a wider iliac peduncle than that of ANSP 10005. Likewise, the curvature of the caudal border of the pubis, ventral to the iliac peduncle, forms a more asymmetrical arch than in ANSP 10005. Pending first hand examination of the specimens, we tentatively conclude that this Mexican hadrosaurid is probably not *H. fouldii*. There are at least two alternative hypotheses to considering the upward curvature of the ischial shaft as an autapomorphy for *H. fouldii*. First, the length and slenderness of the ischial shaft makes it highly susceptible to distortion, for example, during fossil diagenesis. Second, the orientation of the ischial shaft, whether subhorizontal or slightly curved caudoventrally, is variably shared by several taxa and we know of no instances in which either of such conditions is autapomorphic. For example, *Parasaurolophus cyrtocristatus* (FMNH P27393) and *Gilmoresaurus mongoliensis* (AMNH 6551) have ischial shafts that curve downwards distally, whereas many other taxa such as *B. canadensis* (MOR 794), *Prosaurolophus maximus* (ROM 787), and *Gryposaurus incurvimanus* (ROM 764) display straight shafts. Hence, if the upward curvature of the ischial shaft is real, it could be probably a synapomorphy between *H. fouldii* and other forms (whether *Kritosaurus* or other taxa) represented by these other ischia. However, the available material does not allow choosing from all these different possibilities. Therefore, we prefer not to regard the upward curvature of the ischial shaft as autapomorphic for *H. fouldii* until more conclusive data are available.

A few additional specimens from the Late Cretaceous of New Jersey have been labeled as belonging to *H. fouldii* in the collections of the AMNH and the ANSP, although there is no character supporting such assignments to the exclusion of other hadrosaurids. These specimens are: AMNH 1460, a partial centrum (unrecorded locality and horizon); AMNH 7626, a partial right dentary (recovered 6 miles NW of Freehold, New Jersey; unknown horizon); ANSP 15716, the distal half of left humerus (no locality recorded, probably Woodbury Formation, Campanian); and ANSP 15717, a partial metatarsal III (Woodbury Creek, Gloucester County, New Jersey; Woodbury Formation, Upper Cretaceous, Campanian). These specimens are referred here to Hadrosauridae indeterminate.

In conclusion, it is not possible to unequivocally diagnose and distinguish *H. fouldii* from all other hadrosaurid genera and species. Therefore, *H. fouldii* must be regarded a *nomen dubium*.

Implications for the type of Hadrosauridae and Hadrosaurinae

Then, the question arises: can *Hadrosaurus* nomen dubium still be the type genus of Hadrosauridae and Hadrosaurinae? When considering the Linnean system, the International Code of Zoological Nomenclature (ICZN) states, in article 64 and regarding the choice of a type genus for a family group, that any nominal genus included in the family is eligible. Likewise, the Code recommends that the type genus should be well known and representative of the family. It is unclear what the precise meaning of “well known” is, but if it refers to complete knowledge of the anatomy of a taxon, the genus *Hadrosaurus* would not follow this recommendation. However, although the anatomy of *Hadrosaurus* is partially known, what has been preserved is certainly representative of Hadrosauridae. In article 75.5, the ICZN states that when a type species is a *nomen dubium* (and universality and stability are threatened) a neotype may be designated instead upon request to the International Commission of Zoological Nomenclature. However, in the situation of a dubious type, the ICZN does not necessarily require the designation of a neotype, but it is left to the judgment of the author. Article 64 also states that the new type genus determines the stem of the family name. Thus, if we choose to set aside *Hadrosaurus* and select another genus as a neotype of Hadrosauridae, the name of the family would change accordingly. In this regard, we choose not to do so because substituting the use of Hadrosauridae for another name might create confusion in order to solve what is just a nomenclatural formality. The name Hadrosauridae has been in use for so long and it is so widespread, that we think it is more convenient to preserve it. Other specimens within the genus *Hadrosaurus* could be designated as neotype, which would not require changing the stem name of the clade Hadrosauridae. However, the holotype of *H. fouldii* is still the best choice for a type genus and species. This is because, as we will show in our revision of other species erected under the genus *Hadrosaurus*, these taxa are also *nomina dubia* and more incompletely and poorly preserved than the holotype of *H. fouldii*.

If one prefers to use a phylogenetic system of nomenclature as represented by the PhyloCode (Cantino and de Queiroz 2004), *H. fouldii* (or its holotype) must be an internal specifier in the phylogenetic definition of the clade name Hadrosauridae. In the PhyloCode, which provides names for clades without mandating a rank, a specifier is a species, specimen or apomorphy that acts as a reference point to specify the clade to which the name applies. When a name accepted under the ICZN is converted to a clade name under the PhyloCode, one of the internal specifiers of the clade name must be its type species under the ICZN (PhyloCode Art. 11.8). This rule promotes consistency between the names used under the two systems. If it is questionable whether the type specimen of the type species of a preexisting name belongs to the clade to be named, then that species

should not be used as an internal specifier, and the corresponding name should not be used for that clade (PhyloCode Rec. 11.8B). However, this recommendation does not apply in the present case. Although ANSP 10005 is incomplete, our phylogenetic analysis demonstrates that it belongs to Hadrosauridae, so *H. foulkii* can and should be used as an internal specifier for this clade name.

In conclusion, we recommend preserving *Hadrosaurus* and *H. foulkii* as the type genus and type species, respectively, of Hadrosauridae. However, because the membership of *H. foulkii* to the Hadrosaurinae is only tentative and not fully reliable (see below), we prefer to wait until further data are available in order to provide a conclusive answer as to whether this taxon can remain the type genus and species of this clade.

Is *Hadrosaurus Gryposaurus* and/or *Kritosaurus*?

During the last three decades, *Hadrosaurus* has been synonymized (Baird and Horner 1977; Brett-Surman 1979), compared (Davies 1983), distinguished (Ostrom 1961; Weishampel and Horner 1990), and closely related (Brett-Surman 1975, 1989; Wagne 2001) to *Gryposaurus* or *Kritosaurus*. Because clarifying the taxonomy of *Kritosaurus* and *Gryposaurus* lies beyond the scope of this paper, we will follow Horner et al. (2004) in regarding *Gryposaurus* as comprising three species, *G. notabilis* (Lambe, 1914), *G. incurvimanus* (Parks, 1920a) and *G. latidens* (Horner, 1992), and Williamson (2000) in restricting *Kritosaurus* to *K. navajovius* [Brown, 1910; synonymized in Williamson (2000) with *Naashoibito-saurus ostromi* and *Anasazisaurus horneri*].

Carpenter (1982) and Davies (1983) found *Hadrosaurus* to be different from *Gryposaurus* on the basis of dental papillation. However, Coombs (1988) pointed out that isolated teeth are not useful for diagnosing hadrosaurid lower taxa because features such as dental papillation and tooth size vary along the tooth row. Thus, features seen within both dentary and maxillary *H. foulkii* teeth, such as well-developed papillae, indicate nothing regarding their taxonomic identity at generic and specific levels. Still, *G. latidens* (AMNH 5465) dentary teeth, as well as those from a juvenile *Gryposaurus* sp. (ROM 1939), have remarkably wider crowns than *H. foulkii*. This great crown breadth is consistent also throughout the dentary and maxilla. Thus, this condition indicates that at least *H. foulkii* is not *G. latidens*. However, the teeth of *H. foulkii*, *G. incurvimanus* (TMP 80-22-1), and *K. navajovius* (AMNH 5799, as seen in Brown 1910) cannot be distinguished regarding the crown morphology of the enameled surface, except in the greater development of papillae in the former. But because this is also the case between *H. foulkii* and other taxa (e.g., *M. peeblesorum*, OTM F138), teeth neither support nor refute the synonymy of *Hadrosaurus* and *Gryposaurus*.

The ANSP maxillary fragments are too incompletely preserved to allow discrimination from other hadrosaurid maxillae. The dorsoventral thickness of the dorsal border on the medial side of ANSP 9203, adjacent to the dorsal margin of the alveoli, comprises 25% of the total dorsoventral depth of the maxillary fragment. This feature indicates that in the middle region of the complete maxilla the line of alveolar foramina would be located within the dorsal third or fourth of the maxilla, ventral to the dorsal process. This condition is also present in species of *Gryposaurus* (e.g., MOR 478-5-28-8-1), as well as in *K. navajovius* (NMMNH P-16106), and also in other genera such as, for example, *Prosaurolophus* (MOR 454-6-24-6-2), *Saurolophus* (AMNH 5221) and *Edmontosaurus* (CMN 2289). Thus, these specimens neither support nor refute a potential synonymy of *Hadrosaurus* and *Gryposaurus*.

Davies (1983) concluded that *Hadrosaurus* is different from *Gryposaurus* on the basis of comparisons of the humeri, femora, ilia, caudal vertebrae, and metatarsals of ANSP 10005 with those featured in illustrations of *Gryposaurus* (*G. incurvimanus* in Parks 1920b, ROM 4514 in Davies thesis, but today catalogued as ROM 764; and *G. notabilis* in Pinna 1979, specimen MCSNM v345). Davies (1983) contrasted the different angulation of the neural spine of the caudal vertebrae of *Gryposaurus* with the one preserved in ANSP 10005. However, as correctly pointed out by Wagner (2001), the angulation of the neural spines in caudal vertebrae varies along the series, so that more distal vertebrae have more inclined neural spines. Thus, Davies (1983) may have compared vertebrae from different locations in the tail of these taxa. Davies also provided several length ratios between appendicular elements, such humerus/radius, femur/tibia, and hindlimb/forelimb. The values of these ratios are very similar between *H. foulkii* and *Gryposaurus*.

The coracoid of ANSP 10005 is too incompletely preserved to allow precise correspondence with those in other taxa. Still, when compared with *Gryposaurus* (AMNH 5465 and ROM 764), the glenoid in *H. foulkii* appears broader transversely. However, preservational mediolateral crushing (e.g., present in AMNH 5465) is likely to account for this difference.

The humerus of *H. foulkii* differs from that in species of *Gryposaurus* and *K. navajovius* in having a deltopectoral crest that comprises less than 50% of the length of the element (as correctly stated by Davis [1983]), whereas in the other taxa the deltopectoral crest extends to at least 50% or more of the length of bone (e.g., ROM 764, MOR 399 and 478, NMMNH P-16106, AMNH 5350 and 5465). Furthermore, in *H. foulkii*, the craniolateral corner of the crest is smooth and rounded, whereas in many *Gryposaurus* humeri this region is very angular and orthogonal with respect to the humeral shaft (e.g., AMNH 5350 and 5465, ROM 764). Thus, it is unlikely that the humerus of ANSP 10005 could belong to a species of *Gryposaurus*.

Both the radius and the ulna of ANSP 10005, especially the former, have thicker shafts relative to their length than that

of *G. incurvimanus* (e.g., ROM 764), *G. notabilis* (CMN 2278), and some specimens of *G. latidens* (e.g., AMNH 5465; but not MOR 478, which, although it is mediolaterally crushed, is similar in proportions to ANSP 1005). However, robustness is expected to be variable among the individuals of a given hadrosaurid taxon (e.g., in *B. canadensis*, compare the much more robust appendicular elements of MOR 794 relative to MOR 1071, even though they are the same length).

For the femur, Davies (1983) noticed differences in the morphology of the fourth trochanter between ANSP 10005 and *G. incurvimanus* (ROM 764). However, the caudal margin of the fourth trochanter in ANSP 10005 is incompletely preserved. Comparisons of the femur, tibia, fibula, metatarsals II and IV, and phalanx III1 of ANSP 10005 with those of several *Gryposaurus* specimens (ROM 764, AMNH 5350, 5465, ROM 2278, MOR 478), as well as *K. navajovius* (NMMNH P-16106) only revealed differences in robustness. For example, the tibia in *H. fouldkii* has a thicker mid shaft for its length than the one in *G. incurvimanus* (ROM 764). Likewise, the fibulae of *G. latidens* (AMNH 5465) is proportionally longer and its shaft begins to thin more distally than in ANSP 10005. Again, our current understanding of the variation of these elements among hadrosaurids do not allow to discriminate whether these differences are due to ontogeny, individuals of the same age being more or less robust, differences in growth rates, taxonomy, or a combination of all these factors.

Regarding the pelvic girdle of *Hadrosaurus*, the pubic fragment is too incomplete to be compared with other hadrosaurids. Davies (1983) pointed out that the supracetabular process of the ilium of *G. incurvimanus* (ROM 764) is more robust and ventrally deflected than in ANSP 10005. Nevertheless, in ANSP 10005 the lateral margin of the supracetabular process is missing. The depression on the dorsal margin of the ilium at the level of this process is similar in both specimens. In *G. latidens* (AMNH 5465) the supracetabular process is craniocaudally wider than in *H. fouldkii*. However, the degree of development of the supracetabular process varies among hadrosaurids (e.g., *Edmontosaurus* ilia in CMN 2289, ROM 867 and 801). In ANSP 10005 the caudal protuberance of the ischial peduncle appears more pronounced than in ROM 764, but the feature is eroded in the last specimen. In *G. latidens* (MOR 478, AMNH 5465) the preacetabular process is proximally shallower than in ANSP 10005. However, in ANSP 10005 this region is heavily reconstructed with plaster, which probably contributes to the apparent depth of the proximal region of the preacetabular process. However, the thickness of the preacetabular process as it curves cranioventrally in ANSP 10005 is unaffected by the reconstruction. In this regard, the ilium of *G. latidens* (AMNH 5465) differs from ANSP 10005 in having a deeper preacetabular at two thirds of its length. Thus, in view of these differences it is likely, but not certain, that the ilium of ANSP 10005 does not belong to a species of *Gryposaurus*.

Whereas in the ischium of ANSP 10005 the shaft curves upward, in *G. incurvimanus* (ROM 764) the ischial shaft is subhorizontal and has a very slight ventral deflection dis-

tally. We have not observed any other ischia unequivocally referable to species of *Gryposaurus* that we could use for more comparisons.

In conclusion, the synonymy of *Hadrosaurus* with *Gryposaurus* is not supported by the present osteological data, primarily from differences in the humerus and ilium. It is more likely that ANSP 10005 represents a separate taxon, probably at the generic level. Still, this matter could only be settled when more complete cranial material is found for *Hadrosaurus* and when a more exhaustive understanding of the meaning (taxonomic, ontogenetic, polymorphic) of the variation of postcranial elements in hadrosaurid dinosaurs is achieved.

Phylogenetic position of *Hadrosaurus fouldkii*

Since Cope's 1869 erection of Hadrosauridae, there has been consensus regarding the placement of *H. fouldkii* within this clade. Later, Lambe regarded *H. fouldkii* as "most probably a non-crested form, reliance being placed on the evidently pointed termination of its ischium" (Lambe 1918: 138). Ostrom (1961) recognized the uncertainty in considering *H. fouldkii* a hadrosaurine because the type genus lacks the elements that would display the characters of that clade, including the termination of the ischium. However, he preferred to maintain the inclusion of *H. fouldkii* within Hadrosaurinae until proved otherwise for practical purposes "in order to preserve the value of this category and minimize hadrosaurian synonymy" (Ostrom 1961: 49). Since then, *H. fouldkii* has been regarded a hadrosaurine hadrosaurid (Weishampel and Horner 1990; Horner et al. 2004), and, in some cases, closely related to species of *Gryposaurus* and/or *Kritosaurus* (Brett-Surman 1989; Wagner 2001; but see above).

In order to test the hypothesis that *H. fouldkii* is a hadrosaurine hadrosaurid and to elucidate its phylogenetic relationships with other taxa, we conducted a maximum parsimony phylogenetic analysis of *H. fouldkii* along with 12 other hadrosaurids, from which complete skeletal representation is known, and *Iguanodon* as outgroup taxon. These taxa were scored for 60 cranial and 30 postcranial characters (Appendix 1) extracted from a recent character list by Horner et al. (2004) containing 105 characters; 15 characters were not included for being phylogenetically uninformative among the ingroup taxa and, at the same time, were based on anatomical regions missing in the *H. fouldkii* holotype. Character polarity was determined by outgroup comparison. The data (Appendix 2) were analyzed using the branch-and-bound option in PAUP version 4.0b10 (Swofford 2002). Characters were equally weighted and left unordered. Transformations were allowed to be both accelerated and delayed in separate analyses, and the results compared for character optimization. The analysis resulted in 435 equally most parsimonious trees of 149 steps each (C.I. = 0.732, R.I. = 0.759). The strict consen-

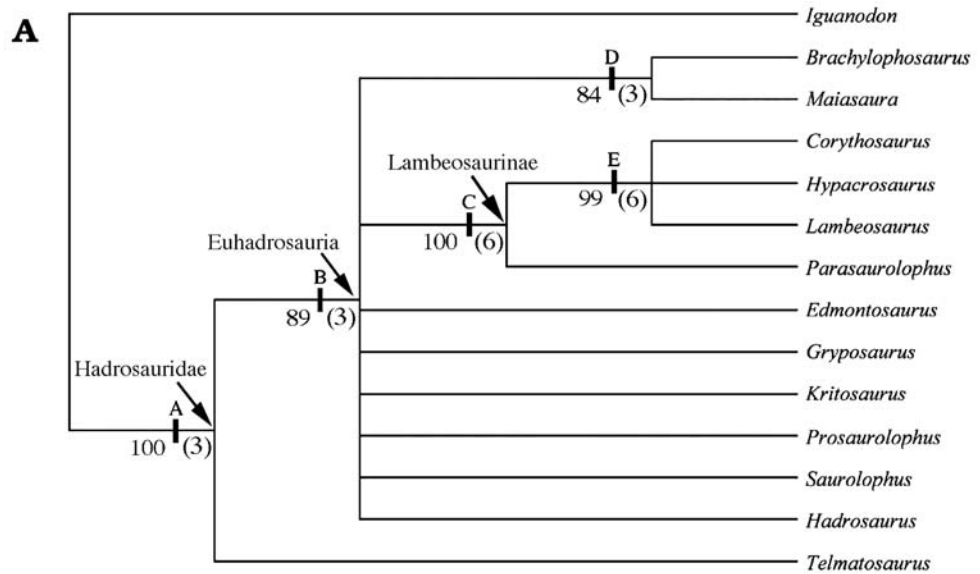

A: 2(1), 5(1), 13(1), 39(2), 40(1), 44(1), 52-53(1), 62(1), 65(1), 86(1).

B: 6(1), 64(1), 76-77(1), 85(1).

C: 21(1), 23(3), 27(1), 36-37(1), 41(1), 58-59(1), 63(1).

D: 33(1).

E: 8(1), 30(2), 38(1), 46(1), 47(0).

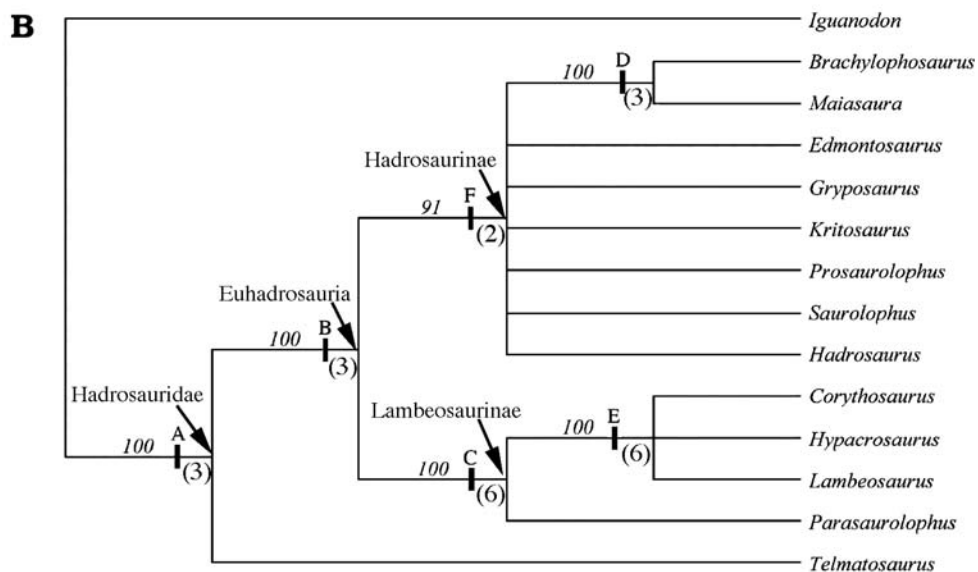

A: 2(1), 5(1), 13(1), 39(2), 40(1), 44(1), 52-53(1), 62(1), 65(1), 86(1).

B: 6(1), 10-12(1), 19(1), 45(1), 48(1), 55-57(1), 60(1), 64(1), 71-78(1), 82(1), 85(1), 87-90(1).

C: 21(1), 23(3), 27(1), 36-37(1), 41(1), 58-59(1), 63(1).

D: 33(1).

E: 8(1), 30(2), 38(1), 46(1).

F: 4(1).

Fig. 5. **A.** Strict consensus cladogram of 435 most parsimonious trees (length = 149, C.I. = 0.732, R.I. = 0.759) showing the phylogenetic position of *Hadrosaurus foulkii* within Hadrosauridae. Letters correspond to the location of synapomorphies supporting the clades (with numbers representing characters and character states, respectively, listed in the Appendix 1). Numbers correspond to bootstrap values after 1000 replicates. Numbers between parentheses are decay indices. **B.** 50% majority rule cladogram showing *H. foulkii* as a member of the Hadrosaurinae. Letters correspond to the location of synapomorphies supporting the clades (with numbers representing characters and character states, respectively, listed in the Appendix 1). Numbers correspond to the majority rule frequencies for each clade. Both ACCTRAN and DELTRAN options resulted in the same distribution of synapomorphies in the estimated phylogenies. Numbers between parentheses are decay indices.

tree (Fig. 5A) positions *H. fouldkii* within Euhadrosauria (*sensu* Weishampel et al. 1993), as part of a polytomy that excludes Lambeosaurinae and the *Brachylophosaurus–Maiasaura* clade. The lack of resolution, as well as the tree not recovering a monophyletic Hadrosaurinae, is primarily due to the “wildcard” effect of *H. fouldkii*, which contains a great amount of missing entries. Thus, deleting *H. fouldkii* from the analysis results in a strict consensus cladogram in which Euhadrosauria is composed of the traditional dichotomy Hadrosaurinae and Lambeosaurinae. However, the 50% majority rule cladogram recovers Hadrosaurinae with the inclusion of *H. fouldkii* with a frequency of 91% (Fig. 5B). We regard this possibility as tentative because only one synapomorphy unites *H. fouldkii* to Hadrosaurinae (i.e., the exclusive presence of a single carina on dentary tooth crowns) and it is possible that the other 9% of the cladograms that do not agree with the 50% majority rule tree could still reflect the actual phylogenetic relationships.

Review of other *Hadrosaurus* species and Hadrosauridae from the East Coast of North America

Hadrosaurus tripos Cope, 1869.

Holotype: USNM 7190, 7093, 7094 and 7095, four caudal centra.

Type locality: Marl pit of W.J. Thompson, Sampson County, North Carolina. Baird and Horner (1979) pointed out that the specimens actually came from the Tertiary Duplin Marl.

Type horizon: The age for the Duplin Marl is Pliocene (Baum and Wheeler 1977; Baird and Horner 1979).

Comments.—A complete description of *H. tripos* is found in Baird and Horner (1979) who regarded these caudal vertebrae as belonging to a balaeonopterid whale. Lull and Wright (1942) also described this specimen and suggested it to be considered a *nomen dubium*. We did not reexamine these specimens, but found no reason to doubt Baird and Horner’s conclusions.

Conclusion.—*H. tripos* is a *nomen dubium*. Not a dinosaur, but a balaeonopterid whale

Ornithotarsus immanis Cope, 1869.

Holotype: YPM 3221, consisting of the articulated left distal tibia, astragalus, calcaneum, and distal fibula fragment.

Type locality and horizon: Although Colbert (1948) pointed out that the stratigraphic position of this taxon is unclear (questionably assigning it to the Campanian Woodbury Formation), both Cope (1869) and Lull and Wright (1942) stated that the bones were discovered in the shores of Raritan Bay (2.5 miles East of Keyport, Monmouth County, New Jersey), from clays belonging to the Lower Cretaceous. No further details were given as to where within the Lower Cretaceous the bones came from.

Comments.—We agree with Lull and Wright (1942) and Colbert (1948) concerning the lack of diagnostic features in YPM 322. However, we could not locate the proximal phalanx

mentioned by Lull and Wright (1942) as assigned to the same taxon. As in all hadrosaurids, the astragalus has a triangular ascending process with a concave cranial surface close to the lateral joint with the calcaneum (Fig. 6A₁, A₂). At its medial edge, the caudal side is as proximodistally tall as the ascending process of the astragalus and slopes lateroventrally until it contacts the calcaneum. The distal surface is saddle-shaped and the bone is twice as long mediolaterally as it is wide craniocaudally. In distal view, the astragalus of YPM 3221 is narrower craniocaudally at the medial side than in *B. canadensis* (MOR 794). The co-ossified calcaneum is crescentic and compact, as in all hadrosaurids. The lateral face is flattened, the distal and caudal surfaces describe a 90-degree convexity, and the bone is proximodistally shorter at the medial articular edge. The proximal surface is convex and split in two parts by a sharp diagonal ridge. The distal fragment of the tibia is non-diagnostic beyond the level of Hadrosauridae, being triangular in both cranial and distal views, and compressed craniocaudally (Fig. 7B). The cranial region has a striated central recess for receiving the ascending process of the astragalus. Lateral to this recess the distal end of the tibia is further expanded distally relative to the medial side. Caudally, there are two flat surfaces; the more extensive one faces caudolaterally and the other caudo-medially. As in all hadrosaurid fibulae, YPM 3221 is distally expanded, approximately twice as wide craniocaudally as it is wide mediolaterally (Fig. 6A₄). The craniolateral distal end is thickened. The medial surface is flat. Lull and Wright (1942) discussed a metatarsal III (ANSP 8596) from marine strata at Merchantville, New Jersey, which they consider comparable to YPM 3221 in size. The bone lacks the ventral half of the proximal region. The element is dorsoventrally compressed (in part due to taphonomic processes), subrectangular, and craniocaudally elongated. The proximal surface is dorsally convex and the distal surface is rectangular in distal profile. The medial ridge gives a smooth convexity to the medial profile of the bone in dorsal view.

Conclusion.—*O. immanis* is a *nomen dubium* due to the lack of distinguishing characters and it is referable to Hadrosauridae indeterminate.

Hadrosaurus minor Marsh, 1870.

Holotype: YPM 1600, an undetermined number of presacral vertebrae.

Referred specimens: YPM 1587, fragment of femur; YPM 1593, dorsal centrum; YPM 745, fragment of femoral shaft, distal half of a tibia, and other fragments; YPM 7896, numerous unidentified fragments; YPM 7898, a left coracoid; ANSP 10007, distal half of a femur; ANSP 15202, right pubis, left and right femora, fragment of left fibula, three caudal vertebrae, a chevron, a cranial dorsal, and three rib and other unidentified fragments.

Type locality and horizon: YPM 1600, YPM 745, and ANSP 10007: Barnsboro, Gloucester County; New Egypt (Navesink) Formation, Upper Cretaceous (Maastrichtian). YPM 1593: Mullica Hill, Gloucester County, New Jersey; New Egypt Formation, Upper Cretaceous. YPM 1587: Swedesboro, New Jersey; Upper Cretaceous, unrecorded strata, probably New Egypt Formation. YPM 153: Barnsboro, New Jersey; unrecorded horizon. YPM 7896 and 7898: West Jersey Marl County,

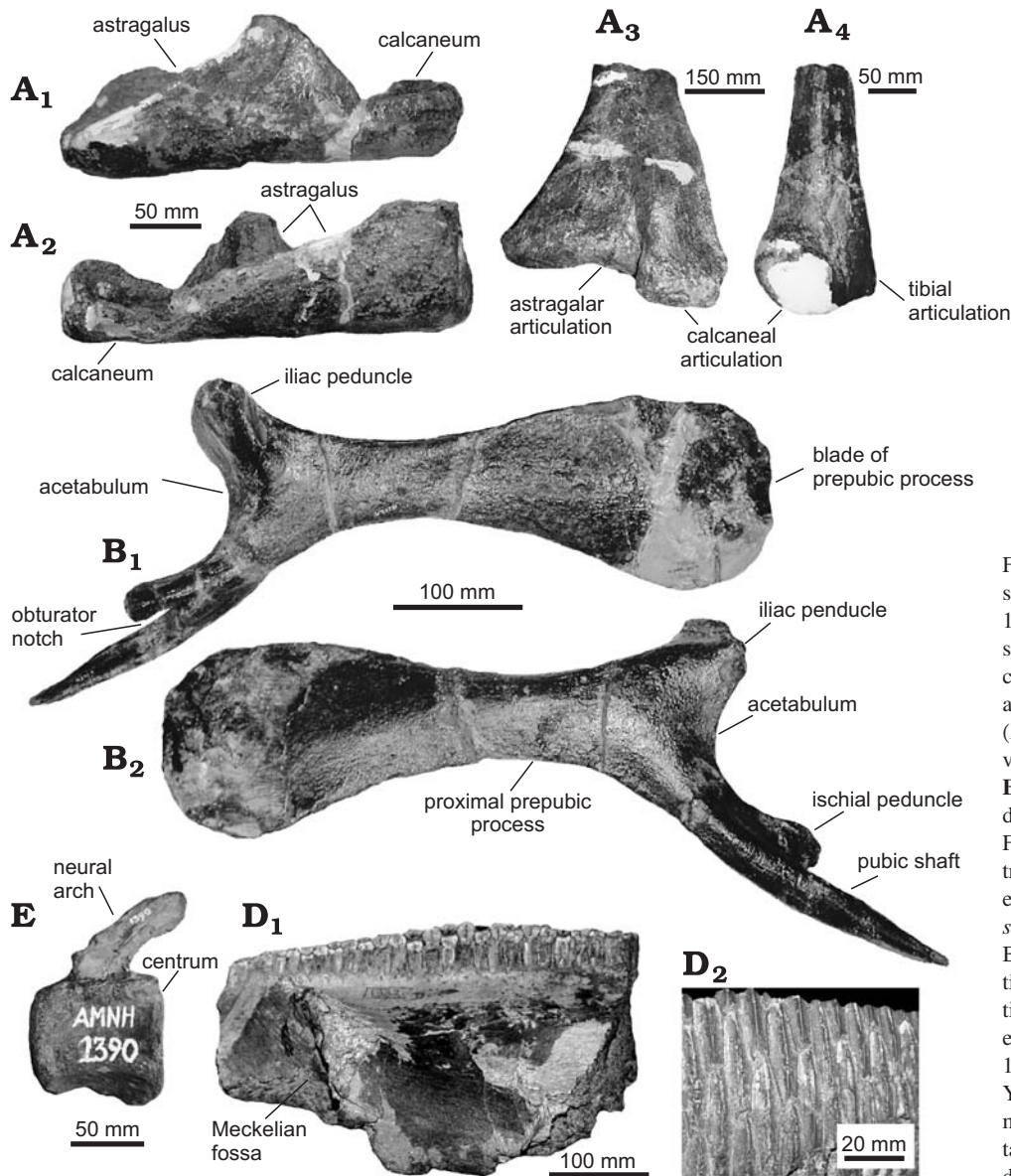

Fig. 6. North American East Coast hadrosaurids. **A.** *Ornithotarsus immanis* Cope, 1869 nomen dubium; Keyport, New Jersey, Monmouth Formation, Lower Cretaceous?, YPM 3221. A₁, A₂. Left astragalus and calcaneum in cranial (A₁) and caudal (A₂) views. A₃. Left distal tibia in cranial view. A₄. Left distal fibula in lateral view. **B.** *Hadrosaurus minor* Marsh, 1870 nomen dubium; Barnsboro, New Jersey, Navesink Formation (New Egypt Formation), Maastrichtian, ANSP 15202, right pubis in lateral (B₁) and medial (B₂) views. **C.** *Hadrosaurus cavatus* Cope, 1871 nomen dubium; Barnsboro, New Jersey, Navesink Formation (New Egypt Formation), Maastrichtian, AMNH 1390, caudal vertebra in lateral view. **D.** *Hadrosaurus breviceps* Marsh, 1889 nomen dubium; Bearpaw Mountain, Yellowstone, Wyoming, Judith River Formation, Campanian, YPM 1779, right dentary in lateral view (D₁), with a detail of the dental battery in lingual view (D₂).

Barnsboro, New Jersey; New Egypt Formation, Maastrichtian. ANSP 15202; Sewell, New Jersey; Navesink Formation, Upper Cretaceous.

Comments.—When Marsh named *H. minor* in 1870 he based his new taxon on non-diagnostic dorsal vertebral centra (YPM 1600). Other specimens catalogued as *H. minor* at the Yale Peabody Museum collection are fragmentary, except for a left coracoid (YPM 7898). The proportions and size of YPM 7898 indicate that it probably pertains to a juvenile individual. As in most hadrosaurid coracoids, the cranial and ventral processes are broken and the element is hook-like cranioventrally. Everything about this element conforms to the typical hadrosaurid coracoid and YPM specimens do not contain diagnostic characters.

In 1948, Colbert described ANSP 15202 and assigned this material to *H. minor* and not to *H. foulkii* due to the smaller size of the former and its much higher stratigraphic occurrence (the Maastrichtian Navesink Formation underlying the Cenozoic along the eastern regions of the sequence;

Colbert 1948). He referred ANSP 15202 to Marsh's taxon on the basis of the size of the elements and the same stratigraphic and close geographic occurrence of YPM 1600 and ANSP 15202. Colbert's diagnosis consists of the small size of the elements relative to *H. foulkii*, the elongation of the proximal constriction of the prepubic process of the pubis (Fig. 6B), and the pointed distal end of the ischium. We were unable to find the ischium in the ANSP collection.

The small size of *H. minor* should not be used for diagnosis because the remains may have belonged to a subadult individual. Muscle scars, such as those on the femoral fourth trochanter of ANSP 15202, are weakly developed compared to those observed in larger (possibly adult) hadrosaurids (viz., MOR 794, *B. canadensis*). It is remarkable that the vertebrae with fused neural arches are caudals, whereas isolated centra lacking neural arches correspond to dorsals (one specimen from ANSP 15202 has its neural arch attached to the centrum with plaster). Among archosaurs, crocodiles have a

neurocentral closure sequence that progresses during ontogeny in a caudal to cranial direction during ontogeny (Brochu 1996). This sequence might also be present in hadrosaurids. Likewise, Colbert (1948) noted that the pubis of ANSP 15202 (Fig. 6B) shows a strong resemblance with that of *Edmontosaurus* and, later, Baird and Horner (1977) later assigned *H. minor* to this hadrosaurine. While it is true that *E. annectens* (as exemplified by AMNH 5370, 5886, and MOR 985) has an elongated and narrow proximal prepubic process, *E. regalis* (e.g., CMN 2289) has a different, much thicker proximal prepubic process (Fig. 7). Although the pubis of ANSP 15202 appears similar to those known from *E. annectens*, a quantification of the proportions of the length and breadth of the proximal and distal regions of the prepubic process in several hadrosaurids shows that ANSP 15202 referral to *Edmontosaurus* is equivocal, due to the variability among the measurements of this genus (Fig. 7).

Conclusion.—*H. minor* is a *nomen dubium*: YPM 1587, 1593, 745, 7896, 7898, and ANSP 10007 and 15202 cannot be diagnosed to any taxonomic level lower than Hadrosauridae. This conclusion is in agreement with Lull and Wright (1942).

Hadrosaurus cavatus Cope, 1871

Holotype: AMNH 1390, four caudal centra.

Type locality and horizon: New Jersey, unrecorded locality; New Egypt Formation, Greensand number 5 beds, Cretaceous (from the collection tag; however, Colbert (1948:34) gives the following information: Swedesboro, New Jersey, “probably Navesink Formation”).

Comments.—AMNH 1390 consists of four centra from the mid section of the tail of an indeterminate hadrosaurid (Fig. 6C). The centra have the hexagonal cranial and caudal surfaces characteristic of hadrosaurids. Two of the specimens preserve a partial neural arch and one centrum preserves a small portion of the neural spine. The reader is referred to Cope (1871) for a detailed description.

Conclusion.—*H. cavatus* is a *nomen dubium* in agreement with previous work (Weishampel and Horner 1990), due to the absence of distinguishing characters.

Hadrosaurus breviceps Marsh, 1889

Holotype: YPM 1779, a partial dentary.

Type locality: Bearpaw Mountain, Yellowstone, Wyoming.

Type horizon: Judith River Formation, Campanian, Upper Cretaceous.

Comments.—This species was briefly described and figured by Marsh in two short papers in 1889 and 1890. Lull and Wright (1942) considered this material to be a species of *Kritosaurus* as *K. breviceps*. YPM 1779 consists of the middle to caudal part of the main body of a dentary (Fig. 6D). Caudally, the specimen includes nearly the last teeth of the dental battery and the rostradorsal portion of the mandibular canal. The ventral portion of the dentary is eroded away. The dentary is relatively wide mediolaterally. There are 27 tooth positions and a maximum of two teeth contributing to the occlusal plane per each position. Tooth crowns are dorso-

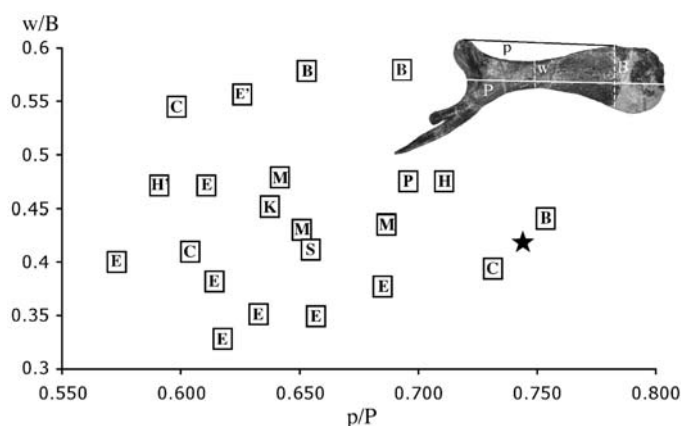

Fig. 7. Relationship between two ratios in the pubis of several hadrosaurid dinosaurs. P, total length of the pubis, from the acetabular edge to the cranial edge of the prepubic process; p, length of the proximal constriction of the prepubic process, from the iliac peduncle to the most proximal and highest point of the dorsal border of the pubic blade; w, minimum breadth of the proximal constriction of the prepubic process; and B, maximum breadth of the pubic blade between the end of “p” and the ventral end of a perpendicular line taken from the end of “p”. The star symbol represents *Hadrosaurus minor* (ANSP 15202). Letters within squares represent the following taxa: B = *Brachylophosaurus canadensis*; C = *Corythosaurus casuarius*; E = *Edmontosaurus annectens*; E' = *E. regalis*; H = *Hypacrosaurus altispinus*; H' = *H. stebingeri*; K = *Kritosaurus latidens*; M = *Maiasaura peeblesorum*; P = *Prosaurolophus blackfeetensis*; S = *Saurolophus osborni*.

ventrally elongate, with a ratio of crown length/width of 3.1 to 3.4 (Fig. 6D₂). The occlusal plane is flat, in contrast to the concave condition observed in *M. peeblesorum*, *B. canadensis*, *Gryposaurus*, and *Edmontosaurus* (Ostrom 1961; Weishampel 1984).

Conclusion.—*H. breviceps* is a *nomen dubium* due to the lack of distinguishable characters; referable to Hadrosauridae indeterminate.

Hadrosaurus paucidens Marsh, 1889.

Holotype: USNM 5457, a nearly complete left squamosal and right maxilla.

Type locality: As indicated by Ostrom (1964), USNM 5457 came from the Dog Creek locality, “about a quarter mile east of the freight road from Judith to Maiden, about 12 miles southeast of Judith, Fergus County, Montana”.

Type horizon: Judith River Formation, Upper Cretaceous (Campanian).

Comments.—This species was first described by Marsh (1889), who later assigned it to a ceratopsian dinosaur (Marsh 1890). More recently, Ostrom (1964) referred USNM 5457 to *Lambeosaurus* on the basis of the erect and high squamosal and the similar morphology of both the maxilla and the squamosal to those of *L. lambei*. Likewise, Ostrom (1964) erected *L. paucidens* for USNM 5457. We did not have the opportunity to examine USNM 5457, but we could make comparisons between the illustrations in Ostrom’s 1964 paper and first hand examination of other hadrosaurids. The maxilla is typically lambeosaurine in structure, with a sloping rostral shelf, but otherwise does not lend itself to a lower level diagnosis of

USNM 5457. Whereas it is true that in both USNM 5457 and *L. lambei* CMN 2869 the squamosal is remarkably high, this condition is variable among and within lambeosaurine taxa. Thus, for example, the skull of another *L. lambei* (ROM 1218) does not have a squamosal that is higher than in other lambeosaurines and is comparable in this regard to the squamosal of *C. casuarius* (e.g., CMN 8676), *P. tubicen* (e.g., PMU R222), *H. altispinus* (e.g., CMN 8501), and *H. stebingeri* (e.g., MOR 548). On the other hand, there are taxa such as *Amurosaurus riabinini* Bolotsky and Kurzanov, 1991 (Godefroit et al. 2004) in which some specimens whose squamosal is as high as that in USNM 5457. Therefore, we reject the great height and erect form of the USNM 5457 squamosal as a character for referring this specimen to *Lambeosaurus*. Additionally, there are remarkable differences between USNM 5457 and *L. lambei* that make these two forms less similar than pointed out by Ostrom (1964). Thus, the dorsal border of the infratemporal fenestra in USNM 5457 is much wider than in *L. lambei*, but comparable to the breadth seen in the other lambeosaurines mentioned above. The quadrate cotylus is about 35% narrower in USNM 5457 than in *L. lambei* (e.g., CMN 2869) and the other lambeosaurines mentioned above. For a detailed osteology of USNM 5457 the reader is referred to Ostrom (1964).

Conclusion: USNM 5457 lacks characters to distinguish *L. paucidens* from *Lambeosaurus* species and other Lambeosaurinae. Thus, it is more appropriate to consider USNM 5457 a Lambeosaurinae indeterminate.

Conclusions

Hadrosaurus fouldii is considered a *nomen dubium* because it lacks unequivocal autapomorphies or any combination of characters that would allow to distinguish this taxon from the remaining known hadrosaurid species. However, this taxon is retained as the type genus and species of the Hadrosauridae to facilitate communication. The osteological data do not support the synonymy or a close relationship of *H. fouldii* with species of *Gryposaurus* and *Kritosaurus*. A systematic review of the other species of *Hadrosaurus* erected since 1858 agrees with previous studies in considering all these taxa *nomina dubia* within Hadrosauridae. *H. paucidens* is referred to Lambeosaurinae indeterminate. Finally, our phylogenetic analysis of *H. fouldii* and a sample of other hadrosaurid taxa indicates that this East Coast dinosaur is a member of Euhadrosauria and, possibly, of Hadrosaurinae.

Acknowledgements

We are thankful to Ted Daeschler (Academy of Natural Sciences of Philadelphia, Pennsylvania), John R. Horner (Museum of the Rockies, Bozeman, Montana), Mark Norell and Carl Mehling (American Museum of Natural History, New York), Daniel Brinkman (Yale Peabody Museum of Paleontology, New Haven, Connecticut), Louis Jacobs and Dale Winkler (Southern Methodist University, Dallas, Texas), Kieran Shep-

herd and Margaret Feuerback (Canadian Museum of Nature, Ottawa, Ontario), Mark Goodwin and Pat Holroyd (University of California, Museum of Paleontology, Berkeley, California), Spencer Lucas and Andrew Heckert (New Mexico Museum of Natural History and Science, Albuquerque, New Mexico), John Peel and Solweg Stuenes (Museum of Evolution, Uppsala University, Uppsala, Sweden), and Kevin Seymour (Royal Ontario Museum, Toronto, Ontario) for provided access to the collections under their care. Gregory Erickson, Scott Steppan, and Paul Gignac (Florida State University, Tallahassee, Florida), David Evans (University of Toronto, Toronto, Ontario), Pascal Godefroit (Institut Royal des Sciences Naturelles de Belgique, Brussels, Belgium), Jonathan R. Wagner (University of Texas, Austin, Texas), Philip Cantino (Ohio University, Athens, Ohio), and Kevin de Queiroz (National Museum of Natural History, Smithsonian Institution, Washington, D.C.) provided helpful comments and advice on various aspects of the manuscript. This project was funded by a Charlotte and Walter Kohler Charitable Trust grant awarded to one of us (A.P.M.).

References

- Anonymous. 1922. The first mounted skeleton of a dinosaur, *Hadrosaurus*. *Natural History* 22: 382–393.
- Baird, D. and Horner, J.R. 1977. A fresh look at the dinosaurs of New Jersey and Delaware. *New Jersey Academy of Science Bulletin* 22: 50.
- Baird, D. and Horner, J.R. 1979. Cretaceous dinosaurs of North Carolina. *Brimleyana* 2: 1–28.
- Bolotsky, Y.L. [Bolockij, Ū.L.] and Kurzanov, S.K. 1991. The hadrosaurs of the Amur Region [in Russian]. In: *Glubinnoe Stroenie Tihookeanskogo Obranleniâ*, 94–103. Amur KNII, Blagoveshensk.
- Brett-Surman, M.K. 1975. *The Appendicular Anatomy of Hadrosaurian Dinosaurs*. 109 pp. Unpublished Master's Thesis, University of California, Berkeley.
- Brett-Surman, M.K. 1979. Phylogeny and palaeobiogeography of hadrosaurian dinosaurs. *Nature* 277: 560–562.
- Brett-Surman, M.K. 1989. *A Revision of the Hadrosauridae (Reptilia: Ornithischia) and their Evolution During the Campanian and Maastrichtian*. 264 pp. Unpublished Ph.D. Thesis, George Washington University, Washington D.C.
- Brochu, C.A. 1996. Closure of neurocentral sutures during crocodylian ontogeny: implications for maturity assessment in fossil archosaurs. *Journal of Vertebrate Paleontology* 16: 49–62.
- Brown, B. 1910. The Cretaceous Ojo Alamo beds of New Mexico with description of the new dinosaur genus *Kritosaurus*. *Bulletin of the American Museum of Natural History* 28: 267–276.
- Cantino, P.D. and de Queiroz, K. 2004. PhyloCode: a phylogenetic code of biological nomenclature. Version 2. <http://www.ohiou.edu/phylocode.html>.
- Carpenter, K. 1982. The oldest Late Cretaceous dinosaurs in North America? *Mississippi Geology* 3: 11–17.
- Carpenter, K., Dilkes, D., and Weishampel, D.B. 1995. The dinosaurs of the Niobrara Chalk Formation (Upper Cretaceous, Kansas). *Journal of Vertebrate Paleontology* 15: 275–297.
- Chapman, R. and Brett-Surman, M.K. 1990. Morphometric observations on hadrosaurid ornithopods. In: P. Currie and K. Carpenter (eds.), *Dinosaur Systematics: Perspectives and Approaches*, 163–178. Cambridge University Press, New York.
- Chin, K. and Gill, B. 1996. Dinosaurs, dung beetles and conifers: participants in a Cretaceous food web. *Palaios* 11: 280–285.
- Colbert, E.H. 1948. A hadrosaurian dinosaur from New Jersey. *Proceedings of the Academy of Natural Sciences of Philadelphia* 100: 23–27.
- Cope, E.D. 1868. Synopsis of the extinct Reptilia found in the Mesozoic and Tertiary strata of New Jersey. In: G.H. Cook (ed.), *Geology of New Jersey*, 733–738. Board of Managers, Daily Advertiser Office, Newark.
- Cope, E.D. 1869. Synopsis of the extinct Batrachia, Reptilia and Aves of North America. *Transactions of the American Philosophical Society* 14: 1–252.

- Cope, E.D. 1874. Review of the Vertebrata of the Cretaceous Period found west of the Mississippi River. *Bulletin of the United States Geological and Geographical Survey of the Territories* 2: 5–48.
- Cope, E.D. 1883. On the characters of the skull in the Hadrosauridae. *Proceedings of the Academy of Natural Sciences of Philadelphia* 35: 97–107.
- Coombs, W.P. 1988. The status of the dinosaurian genus *Diclonius* and the taxonomic utility of hadrosaurian teeth. *Journal of Paleontology* 62: 812–818.
- Davies, K.L. 1983. *Hadrosaurian Dinosaurs of the Big Bend National Park*. 231 pp. Unpublished Master's Thesis, University of Texas at Austin, Austin.
- Dodson, P. 1971. Sedimentology and taphonomy of the Oldman Formation (Campanian), Dinosaur Provincial Park, Alberta (Canada). *Palaeogeography, Palaeoclimatology, Palaeoecology* 10: 21–74.
- Foulke, W.P. 1859. Remarks on fossil bones, shells, and wood, particularly historical remarks on the collection of *Hadrosaurus foulkii* Leidy. *Proceedings of the Academy of Natural Sciences of Philadelphia* 10: 213–215.
- Godefroit, P., Bolotsky, Y.L., and Iltis, J.V. 2004. The lambeosaurine dinosaur *Amurosaurus riabinini* from the Maastrichtian of Far Eastern Russia. *Acta Palaeontologica Polonica* 49: 585–618.
- Hawkins, B.W. 1874. On the pelvis of *Hadrosaurus*. *Proceedings of the Academy of Natural Sciences of Philadelphia* 26: 90–91.
- Hawkins, B.W. 1875. Pelvis of *Hadrosaurus*. *Proceedings of the Academy of Natural Sciences of Philadelphia* 27: 329.
- Hernandez, R., Kirkland, J., Paul, G., Serrano, C.B., and Garcia, J.P. 2003. A large hadrosaurine from the Sabinas basin, Coahuila, Mexico. *Journal of Vertebrate Paleontology* 23: 61A.
- Hopson, J.A. 1975. The evolution of cranial display structures in hadrosaurian dinosaurs. *Paleobiology* 1: 21–43.
- Horner, J.R. 1982. Evidence of colonial nesting and “site fidelity” among ornithischian dinosaurs. *Nature* 297: 675–676.
- Horner, J.R. and Makela, R. 1979. Nest of juveniles provides evidence of family structure among dinosaurs. *Nature* 282: 296–298.
- Horner, J.R. 1992. Cranial Morphology of *Prosaurolophus* (Ornithischia: Hadrosauridae) with Descriptions of Two New Hadrosaurid Species and an Evaluation of Hadrosaurid Phylogenetic Relationships. *Museum of the Rockies Occasional Paper* 2: 1–119.
- Horner, J.R., Weishampel, D. B., and Forster, C. A. 2004. Hadrosauridae. In: D.B. Weishampel, P. Dodson, and H. Osmólska (eds.), *The Dinosauria* 2nd edition, 438–463. University of California Press, Berkeley.
- International Commission on Zoological Nomenclature. 1999. *International Code of Zoological Nomenclature. Fourth Edition*. 306 pp. The International Trust for Zoological Nomenclature, London.
- Lambe, L.M. 1914. On *Gryposaurus notabilis*, a new genus and species of trachodont dinosaur from the Belly River Formation of Alberta, with a description of the skull of *Chasmosaurus belli*. *Ottawa Naturalist* 27: 145–155.
- Lambe, L.M. 1918. On the genus *Trachodon* of Leidy. *Ottawa Naturalist* 31: 135–139.
- Leidy, J. 1856a. Notices of remains of extinct Reptiles and Fishes, discovered by D.F.V. Hayden in the Bad Lands of the Judith River, Nebraska Territory. *Proceedings of the Academy of Natural Sciences of Philadelphia* 8: 72–73.
- Leidy, J. 1856b. Notices of extinct Vertebrata discovered by Dr. F.V. Hayden, during the expedition to the Sioux country under the command of Lieut. G. K. Warren. *Proceedings of the Academy of Natural Sciences of Philadelphia* 8: 311–312.
- Leidy, J. 1858. *Hadrosaurus foulkii*, a new saurian from the Cretaceous of New Jersey, related to *Iguanodon*. *Proceedings of the Academy of Natural Sciences of Philadelphia* 10: 213–218.
- Leidy, J. 1859. *Hadrosaurus foulkii*, a new Saurian from the Cretaceous of New Jersey, related to the *Iguanodon*. *American Journal of Science* 77: 266–270.
- Leidy, J. 1865. Cretaceous reptiles of the United States. *Smithsonian Contributions to Knowledge* 14: 1–13.
- Leidy, J. 1868a. Remarks on a jaw fragment of *Megalosaurus*. *Proceedings of the Academy of Natural Sciences of Philadelphia* 20: 197–200.
- Leidy, J. 1868b. Remarks on *Conosaurus* of Gibbs. *Proceedings of the Academy of Natural Sciences of Philadelphia* 20: 200–202.
- Leidy, J. 1870. Remarks on “*Hadrosaurus* and its allies”. *Proceedings of the Academy of Natural Sciences of Philadelphia* 22: 67–68.
- Lull, R.S. and Wright, N.E. 1942. Hadrosaurian dinosaurs of North America. *Geological Society of America Special Papers* 40: 1–242.
- Lydekker, R. 1888. *Catalogue of the Fossil Reptilia and Amphibia in the British Museum (Natural History), Cromwell Road, S.W. Part I. Containing the Orders Ornithosauria, Crocodilia, Dinosauria, Squamata, Rhynchocephalia, and Protosauria*. 309 pp. Trustees, British Museum (Natural History), London.
- Marsh, O.C. 1872. Notice on a new species of *Hadrosaurus*. *American Journal of Science* 3: 301.
- Marsh, O.C. 1881. Principal characters of the American Jurassic dinosaurs, part IV. *American Journal of Science* 21: 417–423.
- Marsh, O.C. 1889. Description of new American Dinosauria. *American Journal of Science* 37: 331–336.
- Marsh, O.C. 1890. Description of new dinosaurian reptiles. *American Journal of Science* 39: 81–86.
- Norman, D.B. and Weishampel, D.B. 1985. Ornithopod feeding mechanisms: their bearing on the evolution of herbivory. *American Naturalist* 126: 151–164.
- Ostrom, J.H. 1961. Cranial morphology of the hadrosaurian dinosaurs of North America. *Bulletin of the American Museum of Natural History* 122: 33–186.
- Ostrom, J.H. 1964. The systematic position of *Hadrosaurus* (*Ceratops*) *paucidentis* Marsh. *Journal of Paleontology* 38: 130–134.
- Owen, R. 1842. Report on British fossil reptiles. Part II. *Report of the eleventh meeting of the British Association for the Advancement of Science*, July 1841: 66–204.
- Papp, M.J. and Witmer, L.M. 1998. Cheeks, beaks, or freaks: a critical appraisal of buccal soft-tissue anatomy in ornithischian dinosaurs. *Journal of Vertebrate Paleontology* 18: 69A.
- Parks, W.A. 1920a. Preliminary description of a new species of trachodont dinosaur of the genus *Kritosaurus*, *Kritosaurus incurvimanus*. *Transactions of the Royal Society of Canada, Series 3* 13: 51–59.
- Parks, W.A. 1920b. The osteology of the trachodont dinosaur *Kritosaurus incurvimanus*. *University of Toronto Studies, Geology Series* 11: 1–76.
- Pinna, G. 1979. Osteologia dello scheletro di *Kritosaurus notabilis* (Lambe, 1914) del Museo Civico di Storia Naturale di Milano. *Memorie della Società Italiana di Scienze Naturali e del Museo Civico di Storia Naturale di Milano* 22: 33–56.
- Prieto-Márquez, A., Weishampel, D.B., and Horner, J.R. 2003. Taxonomy and systematics of the holotype of *Hadrosaurus foulkii* (Dinosauria, Ornithopoda) from the Late Cretaceous of Eastern North America. *Journal of Vertebrate Paleontology* 23: 88A.
- Ruschenberger, W.S.W. and Tryon, G.W. 1879. *Guide to the Museum of the Academy of Natural Sciences of Philadelphia*. 128 pp. Academy of Natural Sciences, Philadelphia, Pennsylvania.
- Seeley, H.G. 1887. On the classification of the fossil animals commonly named Dinosauria. *Proceedings of the Royal Society of London* 43: 165–171.
- Sereno, P.C. 1986. Phylogeny of the bird-hipped dinosaurs (Order Ornithischia). *National Geographic Research* 2: 234–256.
- Swofford, D.L. 2002. *Phylogenetic Analysis Using Parsimony (and other methods). Version 4.0b10*. Sinauer Associates, Sunderland, Massachusetts.
- Warren, L. 1998. *Joseph Leidy: The Last Man Who Knew Everything*. 352 pp. Yale University Press, New Haven.
- Wagner, J.R. 2001. *The Hadrosaurian Dinosaurs (Ornithischia: Hadrosauria) of Big Bend National Park, Brewster County, Texas, with Implications for Late Cretaceous Paleozoogeography*. 417 pp. Unpublished Master's Thesis, Texas Tech University, Austin.
- Weishampel, D.B. 1981. Acoustic analyses of potential vocalization in lambeosaurine dinosaurs (Reptilia: Ornithischia). *Paleobiology* 7: 252–261.

- Weishampel, D.B. 1984. Evolution in jaw mechanics in ornithomimid dinosaurs. *Advances in Anatomy, Embryology and Cell Anatomy* 87: 1–110.
- Weishampel, D.B. and Horner, J.R. 1990. Hadrosauridae. In: D.B. Weishampel, P. Dodson, and H. Osmólska (eds.), *The Dinosauria*, 534–561. University of California Press, Berkeley.
- Weishampel, D.B., Norman, D.B., and Grigorescu, D. 1993. *Telmatosaurus transylvanicus* from the Late Cretaceous of Romania: the most basal hadrosaurid. *Palaeontology* 36: 361–385.
- Weishampel, D.B. and White, N. 2003. *The Dinosaur Papers: 1676–1906*. 524 pp. Smithsonian Institution Press, Washington, D.C.
- Weishampel, D.B. and Young, L. 1996. *The Dinosaurs of the East Coast*. 275 pp. Johns Hopkins University Press, Baltimore.
- Williamson, T.E. 2000. Review of Hadrosauridae (Dinosauria, Ornithischia) from the San Juan Basin, New Mexico. In: S.G. Lucas and A.B. Heckert (eds.), *Dinosaurs of New Mexico. New Mexico Museum of Natural History and Science Bulletin* 17: 191–213.

Appendix 1

Description of characters used in phylogenetic analysis, taken from a character list in Horner et al. (2004). Character 23 has been modified from Horner et al. (2004).

Dentition

1. Number of tooth positions in maxillary and dentary tooth rows: 30 or fewer (0); 34–40 (1); 42–45 (2); 47 or more (3).
2. Maxillary tooth crown length/width ratio at center of tooth row: broad relative to length, ratio less than 2.4:1 (0); elongate and lanceolate, ratio at least 2.5:1 (1).
3. Dentary tooth crown length/width proportions at center of tooth row: relatively broad, ratio of 2.9:1 or less (0); elongate, ratio of 3.2–3.8:1 (1).
4. Dentary teeth, ornamentation on lingual surface: numerous subsidiary ridges present (0); only one or two subsidiary ridges present, located anterior and posterior to primary carina (1); loss of all but primary carina (2).
5. Maxillary teeth, ornamentation on labial surface: subsidiary ridges present (0); loss of all but primary carina (1).
6. Teeth, position of apex: offset to either mesial or distal side, tooth curved distally (0); central, tooth straight and nearly symmetrical (1).

Mandible

7. Dentary, length of diastema between 1st dentary tooth and pre-dentary: short, no more than width of 4 or 5 teeth (0); long, equal to approximately 1/5 to 1/4 length of tooth row (1); extremely long, equal to approximately one third of tooth row (2).
8. Dentary, orientation of dentary anterior to tooth row: moderately downturned, dorsal margin of pre-dentary rests above ventral margin of dentary body (0); strikingly downturned, dorsal margin of anterior dentary extends below the ventral margin of dentary body, premaxillary bill margin extends well below level of maxillary tooth row (1).
9. Pre-dentary triturating surface, orientation: horizontal, oral margin of premaxilla rests on dorsal pre-dentary (0); canted dorsolaterally to form a nearly vertical surface, oral margin of premaxilla broadly overlaps lateral surface of pre-dentary (1).
10. Angular size: large, deep, exposed in lateral view below the surangular (0); small, dorsoventrally narrow, exposed only in medial view (1).
11. Coronoid bone: present (0); absent (1).
12. Coronoid process configuration: apex only slightly expanded anteriorly, surangular large and forms much of posterior margin of the coronoid process (0); dentary forms nearly all of the greatly antero-posteriorly expanded apex, surangular reduced to thin sliver along posterior margin and does not reach to the distal end of the coronoid process (1).
13. Surangular foramen: present (0); absent (1).

Skull

14. Premaxilla, width at oral margin: narrow, expanded laterally less than 2 times width at narrowest point (post-oral constriction), margin ori-

- ented nearly vertically (0); expanded transversely to more than 2 times post-oral width but not more than interorbital width, margin flared laterally into a more horizontal orientation (1); further expanded transversely to width subequal to that across jugal arches (2).
15. Premaxilla, undercut (“reflected”) rim around oral margin: absent (0); present (1).
16. Premaxillary anterior bill margin shape: horseshoe-shaped, forms a continuous semicircle that curves smoothly to post-oral constriction (0); broadly arcuate across anterior margin, constricts abruptly behind the oral margin (1).
17. Premaxillary foramen ventral to anterior margin of external nares which opens onto the palate: absent (0); present (1).
18. Premaxilla, accessory foramen entering premaxilla in outer narial fossa, located anterior to premaxillary foramen: absent (0); present, empties into common chamber with premaxillary foramen, then onto the palate (1).
19. Premaxillae, oral margin with a “double layer” morphology consisting of an external denticle-bearing layer seen externally, and an internal palatal layer of thickened bone set back slightly from the oral margin and separated from the denticular layer by a deep sulcus bearing vascular foramina: absent (0); present (1).
20. Premaxilla, outer (accessory) narial fossa anterior to circumnarial fossa: absent (0); present, separated from circumnarial fossa by a strong ridge (1).
21. Premaxillary posterior processes (PM1, PM2) and construction of nasal passages: posterodorsal premaxillary process short, posterodorsal and posteroventral processes do not meet posterior to external nares, nasal passages not enclosed ventrally, anterior nasal passage roofed by the nasal, external nares exposed in lateral view (0); posteroventral and posterodorsal processes elongate and join behind external opening of narial passages to exclude nasals, nasal passages completely enclosed by tubular premaxillae, left nasal passage divided from right passage, external nares not exposed in lateral view (1).
22. External nares length/basal skull length ratio: 20% or less (0); 30% or more (1).
23. External nares, composition of posteriormost apex: formed entirely by nasal (0); formed mostly by nasal (dorsally) and to a lesser degree by premaxilla (ventrally) (1); formed equally by nasal (dorsally) and premaxilla (ventrally) (2); formed entirely by premaxilla (3).
24. Supraoccipital, ventral margin: bowed or expanded ventrally along midline (0); horizontal, strong ridge developed along supraoccipital-exoccipital suture (1).
25. Circumnarial fossa, posterior margin: absent (0); present (1).
26. Circumnarial fossa, posterior margin morphology: absent (0); present, lightly incised into nasals and premaxilla, often poorly demarcated (1); present, well demarcated, deeply incised and usually invaginated (2).

27. Nasals and anterodorsal premaxilla in adults: flat, restricted to area anterior to braincase, cavum nasi small (0); premaxilla extended posteriorly and nasals retracted posteriorly to lie over braincase in adults resulting in a convoluted, complex narial passage and hollow crest, cavum nasi enlarged (1).
28. Hollow nasal crest, nasal-posterodorsal process of premaxilla (PM 1) contact: absent (0); present, anterior end of nasal fits along ventral edge of premaxilla (1); present, premaxilla and nasal meet in a complex, W-shaped interfingering suture (2).
29. Hollow nasal crest, relative shape of the two lobes of posteroventral process of premaxilla: absent (0); present, anterior lobe higher than posterior lobe (1); present, posterior lobe higher than anterior lobe (2).
30. Hollow nasal crest, shape: absent (0); present, tubular and elongate (1); present, raised into a large, vertical fan (2).
31. Hollow nasal crest, composition of posterior margin of crest: absent (0); present, composed of premaxilla posterodorsal process (PM 1) (1); present, composed of nasal (2).
32. Solid nasal crest over snout or braincase (does not house a portion of the nasal passage): absent (0); present (1).
33. Solid nasal crest, association with posterior margin of circumnarial fossa: absent (0); solid crest present but circumnarial fossa does not excavate side of crest, fossa terminates anterior to solid crest (1); solid crest present, excavated laterally by circumnarial fossa (2).
34. Solid nasal crest, composition: absent (0); solid crest present, composed of nasals (1); solid crest present, composed of frontals and nasals (2).
35. External nares, shape of posterior margin: lunate (0); V-shaped (1)
36. Maxilla, anterodorsal process: with separate anterior process extending medial to the posteroventral process of premaxilla to form part of medial floor of external naris (0); anterior process absent, anterodorsal margin of maxilla forms a sloping shelf under the premaxilla (1).
37. Maxillary foramen, location: opens on anterolateral body of maxilla, exposed in lateral view (0); opens on dorsal maxilla along maxilla-premaxilla suture (1).
38. Maxilla-lacrimal contact: present (0); lost or covered due to jugal-premaxilla contact (1).
39. Maxilla-jugal contact: restricted to finger-like jugal process on posterior margin of maxilla (0); jugal process of maxilla is reduced to a short projection but retaining a distinct facet (1); jugal process of maxilla lost, anterior jugal has an extensive vertical contact with maxilla anterior to orbit (2).
40. Maxilla, location of apex in lateral exposure: well posterior to center (0); at or anterior to center (1).
41. Maxilla, shape of apex in lateral exposure: tall and sharply peaked (0); low and gently rounded (1).
42. Prefrontal shape at anterodorsal orbit rim: prefrontal lies flush with surrounding elements (0); prefrontal flares dorsolaterally to form a thin, everted, wing-like rim around anterodorsal orbit margin (1).
43. Prefrontal shape: smoothly curved laterally (0); anteriorly broad with square anteromedial corner (1).
44. Ectopterygoid-jugal contact: present (0); absent, palatine-jugal contact enhanced (1).
45. Jugal, expansion of anterior end below lacrimal: dorsoventrally narrow, forms little of the anterior orbital rim (0); expanded dorsoventrally in front of orbit, lacrimal pushed dorsally to lie completely above the level of the maxilla, jugal forms lower portion of orbital rim (1).
46. Jugal, shape of anterior end: with distinct anteriorly-pointed process fitting between the maxilla and lacrimal (0); point truncated, smoothly rounded anterior margin (1).
47. Jugal, anteriorly pointed process: absent (0); present, process restricted to dorsal portion of jugal, anterior jugal appears asymmetrical (1); present, process centered on anterior jugal, anterior jugal appears symmetrically triangular in shape (2).
48. Jugal, development of free ventral flange: absent, jugal expands gradually below lower temporal fenestra to meet the quadratojugal-quadrato (0); present, jugal dorsoventrally constricted beneath lower temporal fenestra to set off flange anterior to constriction (1).
49. Jugal flange size, depth of jugal at constriction below lower temporal fenestra/free ventral flange on jugal: small, 0.70–0.90 (0); prominent, well set off from jugal body, 0.55–0.66 (1).
50. Frontal at orbit margin: present (0); excluded by prefrontal-post-orbital contact (1).
51. Frontals, upward doming over braincase in adults: absent (0); present (1).
52. Quadrates, shape of mandibular condyle: mediolaterally broad, lateral and medial condyles subequal in size (0); lateral condyle expanded anteroposteriorly so that condyles appear subtriangular in distal view, lateral condyle longer than medial one (1).
53. Paraquadrate notch: ventral margin of notch extends dorsally to form an acute and well defined opening (0); well defined notch absent, reduced to a poorly defined embayment of quadrato (1).
54. Squamosals on skull roof, separation: widely separated (0); squamosals approach midline, separated by narrow band of parietal (1); squamosals have broad contact with each other (2).
55. Squamosal, shape of posteroventral surface: shallowly exposed in posterior view (0); form a deep, near vertical, well exposed face in posterior view (1).
56. Supraoccipital, inclination: posterior surface nearly vertical (0); posterior surface inclined steeply forward at approximately 45 degrees (1).
57. Transverse width of the cranium in the postorbital region in dorsal view: broad, width maintained from orbit to quadrato head (0); distinctly narrowed at quadrato heads (1).
58. Parietal, midline ridge: straight to slightly downwarped along length (0); strongly downwarped, dorsal margin bends below the level of the postorbital-squamosal bar (1).
59. Parietal crest, length: relatively long, posterior parietal narrow quickly to form the crest, crest more than half the length of upper temporal fenestrae (0); relatively short, parietal crest narrows gradually posteriorly, crest less than half the length of the upper temporal fenestrae (1).
60. Lower temporal fenestra, acute angle between postorbital bar and jugular bar: absent (0); present (1).

Axial skeleton

61. Cervical centra axial length: long (0); shortened so that axial length of centrum is less than height of neural arch (1).
62. Cervicals, shape of zygapophyseal peduncles on arches: low (0); elevated, extend well above the level of the neural canal, zygapophyses long and dorsally arched (1).
63. Dorsal (posterior) and sacral neural spines: relatively short, less than 3 times centrum height (0); elongate, more than 3 times centrum height (1).

Appendicular Skeleton

64. Coracoid, shape of anterior margin: straight or convex, biceps tubercle small (0); concave, large, laterally projecting biceps tubercle (1).
65. Coracoid, anteroventral process: short (0); long, extends well below the glenoid (1).
66. Scapula, orientation of borders of distal blade: divergent (0); subparallel to one another (1).
67. Scapula, shape of distal end: asymmetrical, either dorsal or ventral border longer than the other (0); symmetrical, dorsal and ventral border terminate at same point (1).
68. Deltopectoral crest: short, much less than half the length of the humerus, narrows noticeably distally (0); extends at least to midshaft or longer, distally broad (1).

69. Humeral distal condyles: mediolaterally broad, flare moderately from shaft of humerus (0); compressed mediolaterally, flares little from shaft of humerus (1).
70. Antebrachium length: humerus subequal to or longer than radius (0); radius longer than humerus (1).
71. Carpus: all elements present (ulnare, radiale, intermedium, distal carpals) and fused, metacarpal I fused onto carpus and divergent from rest of manus (0); reduced to two small, unfused carpals (1).
72. Manus, digit 1: metacarpal and one phalanx present (0); entire digit absent (1).
73. Metacarpal III, relative position of proximal end: aligned with those of MC II and IV (0); offset distally relative to MC II and IV (1).
74. Metacarpal, shape: short and robust, width at midshaft/length ratio .2 or greater (0); slender and elongate, width at midshaft/length .15 or less (1).
75. Penultimate phalanges of digits 2 and 3, shape: rectangular, lateral sides subequal in length (0); wedge shaped, medial side significantly shorter than lateral side (1).
76. Ilium, size of supracetabular process (“antitrochanter”): small, projects only as a lateral swelling (0); large, broadly overhangs the lateral side of the ilium and usually extends at least half way down the side of ilium (1).
77. Ilium-pubis articulation: large iliac contribution, pubic peduncle of ilium long, iliac peduncle of pubis small (0); pubic peduncle of ilium short with restricted articular surface, prominent dorsally directed iliac peduncle of pubis (1).
78. Ilium, postacetabular process shape: tapers posteriorly to nearly a point, wide brevis shelf (0); rectangular, no brevis shelf (1).
79. Ilium, postacetabular process size relative to total length of ilium: less than 40% (0); more than 40% (1).
80. Pubis, distal width of prepubic blade: dorsoventrally expanded to no more than twice the depth of the proximal shaft (0); expanded to more than twice the depth of proximal shaft (1).
81. Pubis, length of prepubic shaft constriction: long, dorsoventral expansion restricted to distal process (0); shaft short, dorsoventral expansion begins at base of process (1).
82. Pubis, obturator foramen: closed or partially closed ventrally by tubercle arising from pubic shaft (0); fully open, tubercle absent (1).
83. Ischium, shape of shaft in lateral view: strongly curved downward (0); nearly straight (1); curved upward (2).
84. Ischium, shape of distal end: small knob-like foot (0); large and pendant foot (1).
85. Ilium, shape of dorsal margin: nearly straight (0); distinctly depressed over supracetabular process (“antitrochanter”) and dorsally bowed over base of preacetabular process (1).
86. Femur, development of intercondylar extensor groove: moderately deep, groove fully open (0); very deep, edges of groove meet or nearly meet anteriorly to enclose an extensor tunnel (1).
87. Tarsus, distal tarsals 2 and 3: present (0); absent (1).
88. Metatarsal 1, length: short, thin splint (0); absent (1).
89. Pes, distal phalanges of pedal digits II through IV: axially shortened to disc-like elements with width at least 3 times length (0); greatly shortened, width at least 4 times length (1).
90. Pes, shape of unguals: taper evenly distally, claw-like (0); dorsoventrally flattened and broadened, hoof-like (1).

Appendix 2

Character—taxon matrix used for phylogenetic analysis. ? = missing data; 0–2 = character states (see Appendix 1).

<i>Iguanodon</i>	00000	00000	00000	00000	00000	00000	00001	00000	00000	010?0	00000	00000	00000	00000	010?0	00000	00000	
<i>Brachylophosaurus</i>	21021	12011	11120	11011	01011	10000	01112	00?21	00011	02110	01111	11001	01011	10111	11111	11101	01111	11111
<i>Corythosaurus</i>	11111	11111	11110	10010	1?310	01222	20000	11121	10011	10101	11121	11111	11111	10111	11111	11111	01111	11111
<i>Edmontosaurus</i>	31021	12011	11121	11111	01111	20000	00001	00?21	00111	01100	01111	11001	11011	10110	11111	11111	01101	11111
<i>Gryposaurus</i>	21021	11011	11111	11011	01011	10000	01211	00021	00111	01110	01111	11001	11011	00110	11111	11111	01101	11111
<i>Hadrosaurus</i>	?1021	1????	?????	?????	?????	?????	?????	0????	?????	?????	?????	?????	?????	?????	?????	11???	??2?1	1????
<i>Hypacrosaurus</i>	21111	111?1	11110	10010	1?310	01212	20000	11121	10011	10101	11121	11111	1111?	?1111	?????	11111	11111	11111
<i>Lambeosaurus</i>	21111	11111	11110	10010	1?310	01112	10000	11121	10011	10101	11121	11111	11111	10111	11111	11110	01111	11111
<i>Maiasaura</i>	21021	12011	11120	111?1	00011	10000	01122	00021	01111	02110	11121	11001	01011	00111	11111	11111	01111	11111
<i>Kritosaurus</i>	21021	12011	11121	11011	0?011	10000	01211	00021	00011	01101	01111	11001	11011	0?11?	?????	11101	0??11	11111
<i>Parasaurolophus</i>	21111	10011	11110	100?0	1?310	01001	00001	11021	10011	01101	?1121	11111	11111	10101	11?11	11111	11111	111??
<i>Prosaurolophus</i>	21021	11011	11112	01?11	01211	20000	01211	00021	01011	01100	11111	11001	11011	10110	11111	11111	01101	11111
<i>Saurolophus</i>	31021	11001	11110	00011	00201	20000	01211	00021	01011	01101	11121	11001	11011	00110	11111	11100	01101	11111
<i>Telmatosaurus</i>	01111	000?0	00110	0?000	000?0	00000	00002	00?21	0??10	020?0	01100	00000	110?1	0101?	?????	?????	?????	1????